



New

SCALEMASTER® HP
»High Performance«



SCALEMASTER® HP »High Performance« Descaling Nozzles with Distinctive Advantages

As a result of greater demands on product surface quality and plant efficiency, descaling systems need to perform more effectively and economically than in the past.

The key to improving a descaling process centers on the spray and the nozzle which produces it.

Improvements in the nozzle and spray designs should be focussed on:

- Improving the product quality
- Reducing operating costs
- Reducing chilling of the product by the sprays
- Reducing the pump energy consumption

The SCALEMASTER® system is essential for highly efficient and successful descaling, having been installed in over 200 sites world-wide.

The success of the SCALEMASTER® has led to the development of the new SCALEMASTER® HP (High Performance).

The most obvious benefit for the user of the SCALEMASTER® HP is its significantly increased spray impact density providing even better descaling and higher surface quality.

All components are designed to produce a spray that focusses and concentrates the water energy for maximum impact.

The SCALEMASTER® HP nozzle tips form a perfectly defined, razor sharp spray jet.

Critical elements in the design of the new SCALEMASTER® HP are the following parameters:

- Even impact distribution of each individual spray on the target surface
- Spray angle
- Spray thickness
- Flow rate

Additionally the new SCALEMASTER® HP is produced within tight tolerances for reproducible operating conditions.

Utilising LECHLER's computer-based modelling techniques, we are the first spray nozzle manufacturer who can achieve totally predictable results by optimizing nozzle arrangements and header layouts.

Many rolling mills throughout the world have profited from these computer models, by improving product quality and reducing costs.

The nozzle tips of the SCALEMASTER® HP and MiniSCALEMASTER® HP are interchangeable with those of the standard SCALEMASTER® and MiniSCALEMASTER®

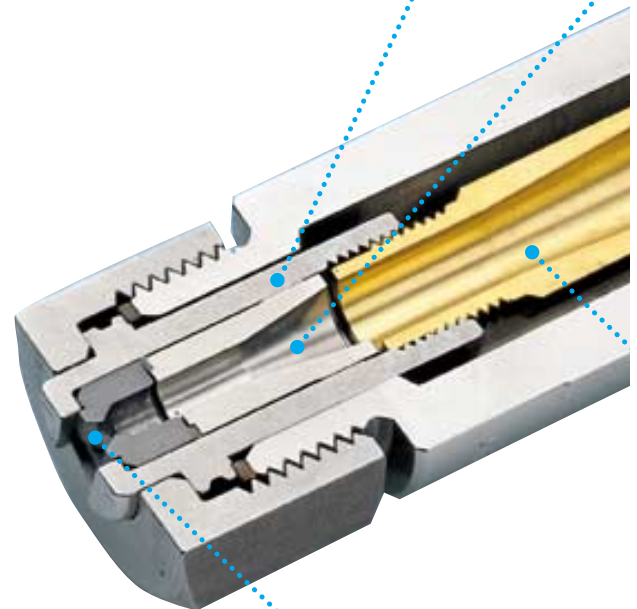

**Improved nozzle geometries within the orifice and flow zone
⇒ reduces wear and improves jet quality**

Optimized parameters in water flow zone
→ maximised water velocity

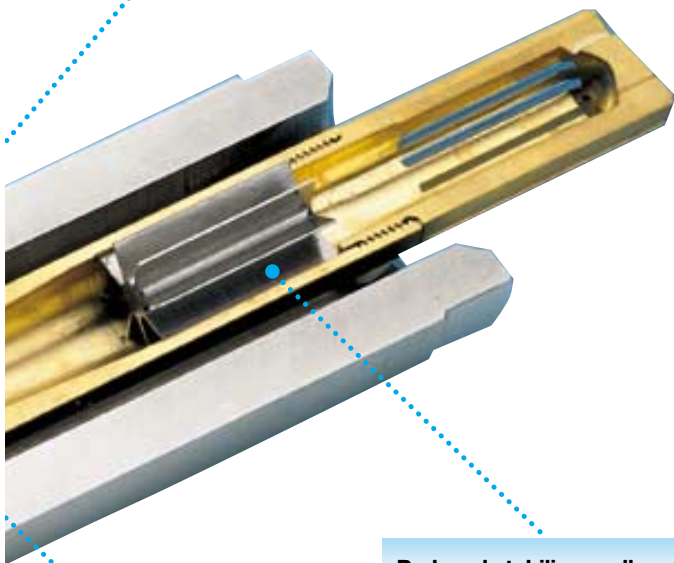

Reduced stabilizer wall thickness
→ reduces flow resistance

Larger flow zone
→ reduces turbulence and improves laminar flow.

SCALEMASTER® HP long life

In areas where special operating conditions occur, i.e. very high spray pressures, unusually high wear of the nozzle orifice will be noticed. For this application LECHLER recommends the long life ver-

sion of the SCALEMASTER® HP. Special nozzle geometries within the orifice and the flow zone improve wear resistance, and thus service life of the nozzle is significantly increased.

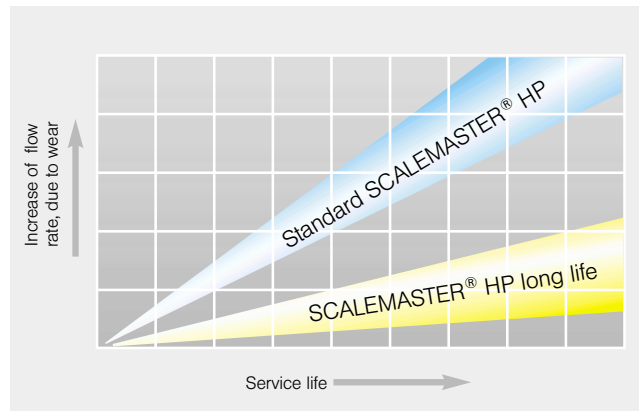

Service life diagram

At given operating conditions the SCALEMASTER® HP **long life** achieves a service life that is 3 to 4 times longer and offers the same impact values as the standard SCALEMASTER® HP.

Standard SCALEMASTER® HP Series 682

The descaling system is available from LECHLER in two distinct designs: The larger 682 series SCALEMASTER® HP and the compact 642 series MiniSCALEMASTER® HP.

The 682 series is designed for use where there are no limitations on available space.

Flow rates and spray angles are determined by the nozzle tips, an identical range being available for both systems.

The minimum pitch (E) between nozzles is determined by the tip retaining nut. For the SCALEMASTER® HP the minimum pitch, using the standard nut (product no. 069.400.11) is 63 mm.

If a closer nozzle pitch is required, LECHLER offers a special retaining nut (product no. 069.402.11). This allows a minimum pitch of 50 mm.

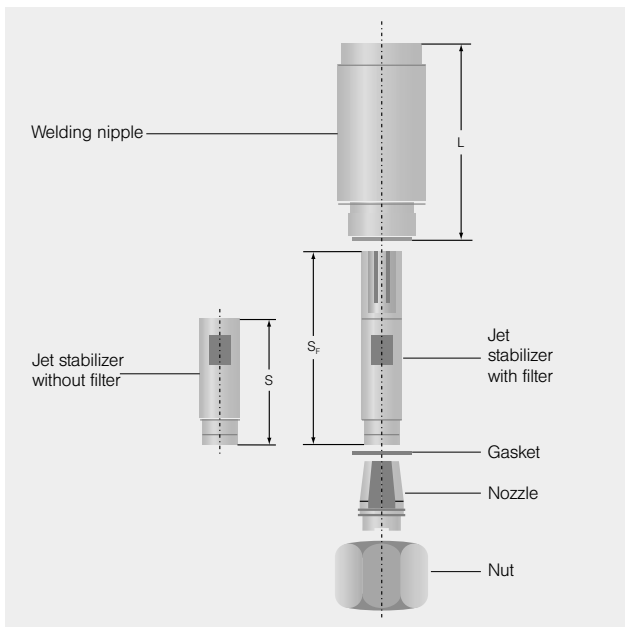
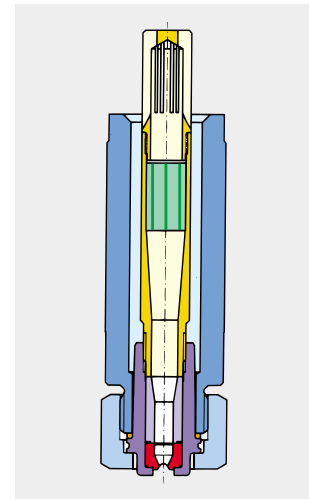

Component		Ordering No.	Weight [kg]
Welding nipple Material: AISI 304	Length: L = 120 mm	069.411.1C.00	0,830
	L = 100 mm	069.410.1C.00	0,690
	L = 73 mm	069.410.1C.73	0,480
Jet stabilizer Material Brass	without filter S = 74	064.231.16	0,070
	without filter S = 94	064.233.16	0,080
	with filter S _F = 110	064.250.16	0,110
	with filter S _F = 130	064.252.16	0,140
	with filter S _F = 150	064.253.16	0,160
Gasket Material: Copper		095.015.34.04.02.0	0,004
Nozzle		682.XXX.XX see table	0,085
Nut (Standard) Material: AISI 431	Hex 41	069.400.11	0,153
Nut with hexagon socket Material: AISI 431	Hex 24/36 see page 5	069.402.11	0,240
Alignment tip/ Blank tip (see page 9) Material: Mild steel	Data sheet on request	069.490.01	0,072
Disassembly tool Material: Mild steel	Data sheet on request	069.491.01	0,140
Tip extractor	Data sheet on request	095.009.00.12.56.0	0,950

Standard SCALEMASTER® HP

Flow Rate Chart

Ordering Data

Ordering No.							Flow rate for water (V̇)					
Type					Mat.-No.		p = 100 bar (1450 psi)		p = 200 bar (2900 psi)		p = 400 bar (5800 psi)	
Series	Code				Tungsten carbide 27	Tungsten carbide long life H7	[l/min]	[US Gall./min]	[l/min]	[US Gall./min]	[l/min]	[US Gall./min]
	Spray angle											
	22°	26°	30°	40°								
682	495	496	497	498	○	-	12,00	3,17	16,97	4,50	24,00	6,34
682	535	536	537	538	○	○	15,00	3,96	21,21	5,60	30,00	7,92
682	565	566	567	568	○	○	18,00	4,76	25,46	6,73	36,00	9,52
682	605	606	607	608	○	○	23,00	6,08	35,53	9,39	46,00	12,16
682	645	646	647	648	○	○	28,00	7,40	39,60	10,46	56,00	14,80
682	685	686	687	688	○	○	36,00	9,51	50,91	13,45	72,00	19,02
682	725	726	727	728	○	○	45,00	11,89	63,64	16,81	90,00	23,78
682	765	766	767	768	○	○	58,00	15,32	82,02	21,67	116,00	30,64
682	805	806	807	808	○	○	72,00	19,02	101,82	26,90	144,00	38,04
682	845	846	847	848	○	○	89,00	23,51	125,87	33,25	178,00	47,02
682	885	886	887	888	○	○	112,00	29,59	158,39	41,85	224,00	59,18
682	-	906	907	908	○	○	125,00	33,03	176,78	46,70	250,00	66,06
682	-	916	917	918	○	○	134,00	35,40	189,50	50,07	268,00	70,80

Example Series + Code + Mat.-No. = Ordering No.
for Ordering: 682 + 495 + 27 = 682.495.27

Volume rate conversion formula:

$$\dot{V}_2 = \sqrt{\frac{p_2}{p_1}} \cdot \dot{V}_1 \text{ [l/min]}$$

$$p_2 = \left(\frac{\dot{V}_2}{\dot{V}_1}\right)^2 \cdot p_1 \text{ [bar]}$$

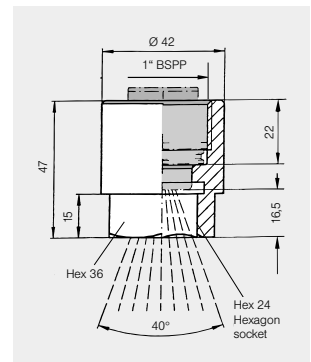

Special nut with hexagon socket.
For very short spray heights.
Ord.-No.: 069.402.11

Dimensions

Type (Spray angle 22°)	E ø [mm]	A ø [mm]	Type (Spray angle 26°)	E ø [mm]	A ø [mm]	Type (Spray angle 30°)	E ø [mm]	A ø [mm]	Type (Spray angle 40°)	E ø [mm]	A ø [mm]
682.495	1,20	1,50	682.496	1,17	1,50	682.497	1,16	1,50	682.498	1,11	1,50
682.535	1,40	1,75	682.536	1,30	1,75	682.537	1,30	1,75	682.538	1,20	1,75
682.565	1,60	2,00	682.566	1,50	2,00	682.567	1,40	2,00	682.568	1,20	2,00
682.605	1,80	2,10	682.606	1,70	2,10	682.607	1,60	2,10	682.608	1,50	2,10
682.645	2,00	2,50	682.646	1,90	2,50	682.647	1,80	2,50	682.648	1,60	2,50
682.685	2,20	2,80	682.686	2,20	2,80	682.687	2,10	2,80	682.688	2,00	2,80
682.725	2,50	3,00	682.726	2,40	3,00	682.727	2,30	3,00	682.728	1,90	3,00
682.765	2,80	3,50	682.766	2,50	3,50	682.767	2,40	3,50	682.768	2,30	3,50
682.805	3,20	3,80	682.806	3,00	3,80	682.807	2,90	3,80	682.808	2,70	3,80
682.845	3,50	4,30	682.846	3,50	4,30	682.847	3,20	4,30	682.848	3,00	4,30
682.885	3,90	4,70	682.886	3,90	4,70	682.887	3,70	4,70	682.888	3,40	4,70
			682.906	4,00	5,00	682.907	3,90	5,00	682.908	3,70	5,00
			682.916	4,20	5,20	682.917	4,00	5,20	682.918	3,80	5,20

A = equivalent bore diameter · E = narrowest cross section

MiniSCALEMASTER® HP

Compact Nozzle System for Lower Spray Heights

Series 642

The MiniSCALEMASTER® HP (642 Series) is a compact system for use where lower spray heights are necessary. Such as in the descaling of thin slabs, beam blanks, rails, billets and rounds.

The minimum spray height (h_2) is normally 50 mm, because the nozzles cannot be physically placed closer together.

If a spray height of less than 50 mm is required, LECHLER offers a special retaining nut (product no. 064.401.11). (See below)

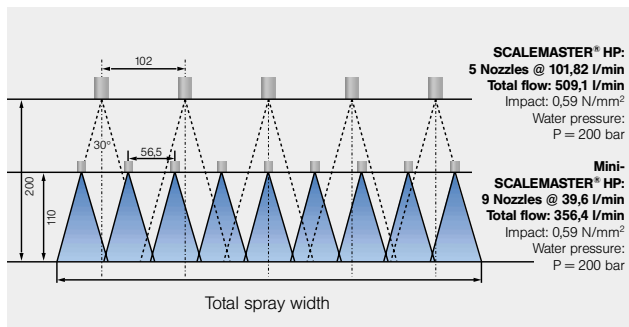

An example of saving water by using MiniSCALEMASTER® HP

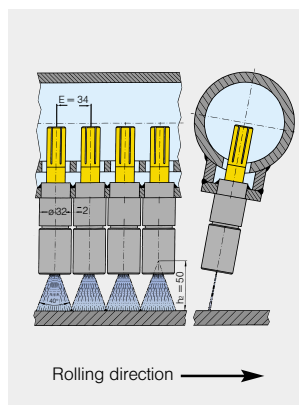

Possible arrangement of welding nipples for MiniSCALEMASTER® HP (with hexagon socket)

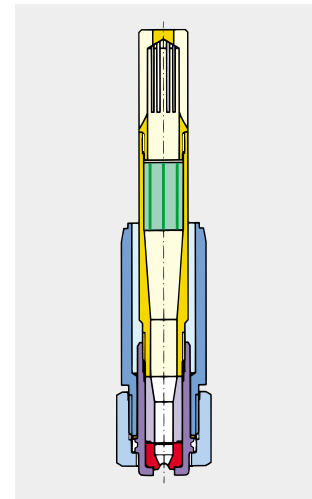
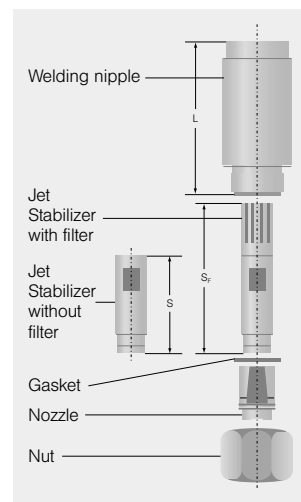

Component		Ordering-No.	Weight [kg]
Welding nipple Material: AISI 304	Length: L = 32 mm	060.020.1C.01	0,065
	L = 39 mm	060.020.1C.00	0,082
	L = 80 mm	060.020.1C.02	0,192
Jet stabilizer Material: Brass	without filter S = 74	064.231.16	0,070
	without filter S = 94	064.233.16	0,080
	with filter S _F = 110	064.250.16	0,110
	with filter S _F = 130	064.252.16	0,140
	with filter S _F = 150	064.253.16	0,160
Gasket Material: Copper		095.015.34.02.070	0,001
Nozzle		642.XXX.XX see table	0,067
Nut (Standard) Material: AISI 431	Hex 32	064.400.11	0,085
Nut with hexagonal socket Material: AISI 431	Hex 22	064.401.11	0,120
Alignment tip/ blank tip (see page 9) Material: Mils steel	Data sheet on request	064.490.01	0,056
Disassembly tool Material: Mild steel	Datasheet on request	064.491.01	0,110
Tip Extractor	Datasheet on request	095.009.00.12.56.0	0,950

MiniSCALEMASTER® HP

Flow Rate Chart

Ordering Data

Ordering No.							Flow rate for water (V̇)					
Type					Mat.-No.		p = 100 bar (1450 psi)		p = 200 bar (2900 psi)		p = 400 bar (5800 psi)	
Series	Code				Tungsten carbide 27	Tungsten carbide long life H7	[l/min]	[US Gall./min]	[l/min]	[US Gall./min]	[l/min]	[US Gall./min]
	Spray angle											
	22°	26°	30°	40°								
642	495	496	497	498	○	-	12,00	3,17	16,97	4,50	24,00	6,34
642	535	536	537	538	○	○	15,00	3,96	21,21	5,60	30,00	7,92
642	565	566	567	568	○	○	18,00	4,76	25,46	6,73	36,00	9,52
642	605	606	607	608	○	○	23,00	6,08	35,53	9,39	46,00	12,16
642	645	646	647	648	○	○	28,00	7,40	39,60	10,46	56,00	14,80
642	685	686	687	688	○	○	36,00	9,51	50,91	13,45	72,00	19,02
642	725	726	727	728	○	○	45,00	11,89	63,64	16,81	90,00	23,78
642	765	766	767	768	○	○	58,00	15,32	82,02	21,67	116,00	30,64
642	805	806	807	808	○	○	72,00	19,02	101,82	26,90	144,00	38,04
642	845	846	847	848	○	○	89,00	23,51	125,87	33,25	178,00	47,02
642	885	886	887	888	○	○	112,00	29,59	158,39	41,85	224,00	59,18
642	-	906	907	908	○	○	125,00	33,03	176,78	46,70	250,00	66,06
642	-	916	917	918	○	○	134,00	35,40	189,50	50,07	268,00	70,80

Example Series + Code + Mat.-No. = Ordering No.
for Ordering: 642 + 495 + 27 = 642.495.27

Volume rate conversion formula:

$$\dot{V}_2 = \sqrt{\frac{p_2}{p_1}} \cdot \dot{V}_1 \text{ [l/min]}$$

$$p_2 = \left(\frac{\dot{V}_2}{\dot{V}_1}\right)^2 \cdot p_1 \text{ [bar]}$$

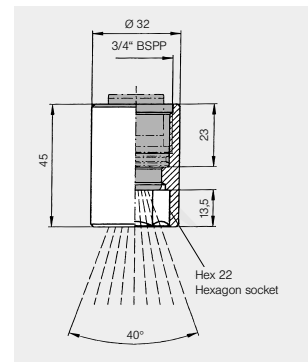

Special nut with hexagon socket.
For very short spray heights.
Ord.-No.: 064.401.11

Dimensions

Type (Spray angle 22°)	E ø [mm]	A ø [mm]	Type (Spray angle 26°)	E ø [mm]	A ø [mm]	Type (Spray angle 30°)	E ø [mm]	A ø [mm]	Type (Spray angle 40°)	E ø [mm]	A ø [mm]
642.495	1,20	1,50	642.496	1,17	1,50	642.497	1,16	1,50	642.498	1,11	1,50
642.535	1,40	1,75	642.536	1,30	1,75	642.537	1,30	1,75	642.538	1,20	1,75
642.565	1,60	2,00	642.566	1,50	2,00	642.567	1,40	2,00	642.568	1,20	2,00
642.605	1,80	2,10	642.606	1,70	2,10	642.607	1,60	2,10	642.608	1,50	2,10
642.645	2,00	2,50	642.646	1,90	2,50	642.647	1,80	2,50	642.648	1,60	2,50
642.685	2,20	2,80	642.686	2,20	2,80	642.687	2,10	2,80	642.688	2,00	2,80
642.725	2,50	3,00	642.726	2,40	3,00	642.727	2,30	3,00	642.728	1,90	3,00
642.765	2,80	3,50	642.766	2,50	3,50	642.767	2,40	3,50	642.768	2,30	3,50
642.805	3,20	3,80	642.806	3,00	3,80	642.807	2,90	3,80	642.808	2,70	3,80
642.845	3,50	4,30	642.846	3,50	4,30	642.847	3,20	4,30	642.848	3,00	4,30
642.885	3,90	4,70	642.886	3,90	4,70	642.887	3,70	4,70	642.888	3,40	4,70
			642.906	4,00	5,00	642.907	3,90	5,00	642.908	3,70	5,00
			642.916	4,20	5,20	642.917	4,00	5,20	642.918	3,80	5,20

A = equivalent bore diameter · E = narrowest cross section

Nozzle Arrangement on a Descaling Header

Positioning of nozzles on a spray header

$$E = C - D$$

$$C = \cos \gamma \cdot B$$

$$\beta = 5^\circ, 10^\circ \text{ or } 15^\circ$$

- A = spray length
- B = spray width
- C = spray width in rolling direction
- D = over lap
- E = nozzle distance
- h_2 = vertical spray height
- α = nozzle spray angle
- β = angle of inclination
- γ = offset angle of nozzle against pipe roll axis

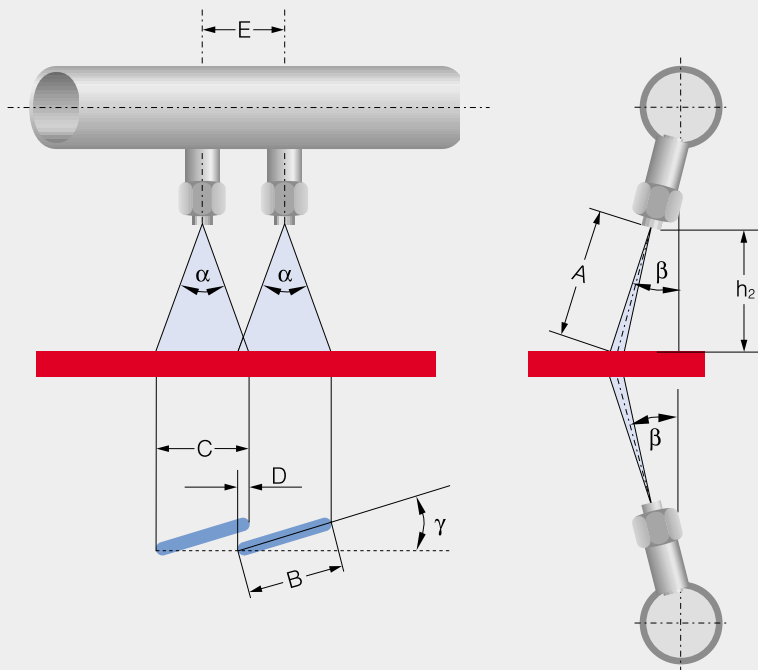

Spray length (A), spray width (B, C), over lapping (D), nozzle distance (E) with vertical spray height (h_2), nozzle spray angle (α) and angle of inclination (β)

Vertical spray height h_2 [mm]	angle of inclination $\beta = 15^\circ$ A [mm]	Nominal nozzle spray angle α at $p = 150$ bar															
		$\alpha = 22^\circ$				$\alpha = 26^\circ$				$\alpha = 30^\circ$				$\alpha = 40^\circ$			
		B	C	D	E	B	C	D	E	B	C	D	E	B	C	D	E
50	52	28	27,0	-	-	34	32,7	-	-	38	36,9	-	-	50	47,3	4	43,8 ²⁾
75	78	40	38,8	4	34,8 ¹⁾	48	45,9	4	41,9 ¹⁾	54	52,3	4	48,3 ²⁾	71	68,3	4	64,3
100	104	52	49,8	5	44,8 ²⁾	60	57,7	5	52,7 ³⁾	69	66,3	5	61,3 ³⁾	90	87,2	5	82,2
150	155	73	70,0	5	65	81	78,3	5	73,3	94	90,9	5	85,9	126	121,2	8	113,2
175	181	82	79,4	5	74,4	91	87,6	5	82,6	106	102,2	5	97,2	142	137,1	8	129,1
200	207	92	88,4	5	83,4	100	96,6	5	91,6	117	113,0	5	108	158	152,4	10	142,4
225	233	101	96,9	5	91,9	109	105,5	5	100,5	128	123,5	5	118,5	174	167,5	10	157,5
250	259	109	104,9	8	96,9	119	114,3	8	106,3	139	134,0	8	126	189	182,4	12	170,4
270	280	115	110,6	8	102,6	126	121,5	8	113,5	148	142,4	8	134,4	202	194,4	12	182,4
300	311	123	118,1	8	110,1	137	132,5	8	124,5	161	155,2	8	147,2	221	212,5	15	197,5

Explanation of the table:

1. Spray width:

The listed values are based on $p = 150$ bar spray pressure. The convergence of the spray is considered in the values of the table. Spray width data for other spray pressures is available on request.

2. Tolerances of the spray angles:

+ 3° at $\alpha = 22^\circ, 26^\circ$ and 30° ,
+ 5° at $\alpha = 40^\circ$.
Therefore B + C are minimum values.

¹⁾ Only MiniSCALEMASTER® HP with hexagon socket nut ²⁾ Only MiniSCALEMASTER® HP ³⁾ Standard SCALEMASTER® only with hexagon socket nut

Nozzle Position Nozzle Assembly

Nozzle Position Options

1. All nozzles offset in one direction. (see fig. 1)
2. All nozzles offset toward the nearest outside edge - sprays directed away from the center of the strip. This results in better drainage and it is easier to guide the strip. (see fig. 2)

Nozzle Arrangements

To guarantee the correct alignment of the nozzle tip (15 degree offset - see fig. 1, 2), the nipple weld nipple must be positioned on the spray header such that the flats on the tip are parallel to the header longitudinal axis. We recommend you do this with our alignment tip (fig. 1, 2, 4). It ensures proper positioning of the nipple during welding. Referring to fig. 3 below, alignment tips are inserted into the base. Then a strip edge is used to easily position and weld each nipple.

One-handed Nozzle Assembly

Descaling headers are often located in areas where it is difficult to reach every nozzle. This is particularly true of nozzles located underneath the rolls where you can often reach the nozzle with one hand only. The new SCALEMASTER® nozzle has been designed to ensure easy assembly in those locations by doing most of the assembly prior to installation. The tip, stabilizer and strainer are assembled as one unit. This assembly unit is then inserted into the base and rotated until the flats are aligned allowing further insertion and cap thread engagement. Thread engagement cannot take place until alignment is accomplished. The cap should not be tightened to more than 250 Nm (Standard SCALEMASTER®) and 200 Nm (MiniSCALEMASTER®) of torque in order to prevent damage to the tip.

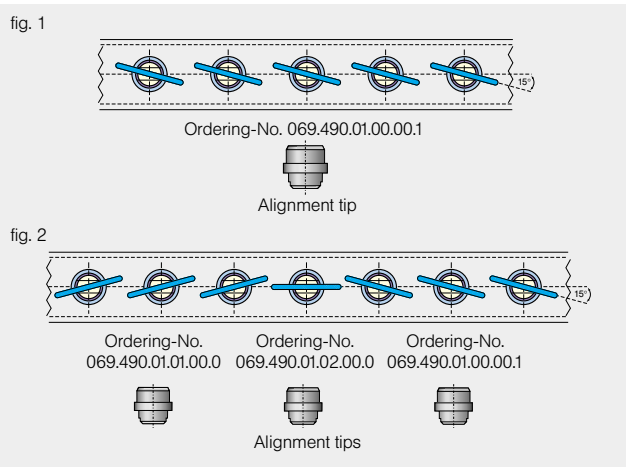

„Automatic“ Adjustment of the Nozzle Tip

The required 15 degree offset is integrated into every nozzle tip. Consequently, assembling the nozzle tip incorrectly is absolutely impossible. Once the cap is tightened, the nozzle is in the proper position.

Equipment

The alignment tip (fig. 1, 2, 4) can also be used as blank tip for blanking off specific nozzle positions or for pressure testing the entire spray header.

General Information

Flow Requirements

The flow velocity should not exceed 5 m/s in the water mains and 1 m/s in the descaling headers.

Nozzle Control

Nozzles are subject to wear. The condition of the water and the environment can both affect nozzle life. Therefore, a regular nozzle inspection program should be established to ensure proper performance of the nozzle at all times. The intervals for such a program must be established at each installation. Factors such as solid contents in the water can cause wide variations in nozzle wear rates.

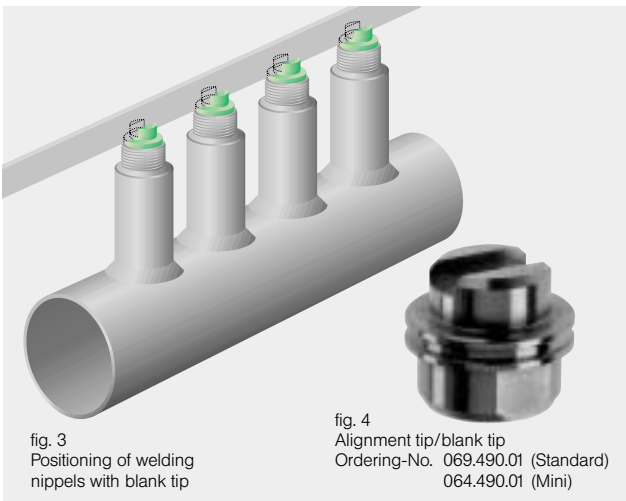

fig. 3
Positioning of welding nipples with blank tip

fig. 4
Alignment tip/blank tip
Ordering-No. 069.490.01 (Standard)
064.490.01 (Mini)

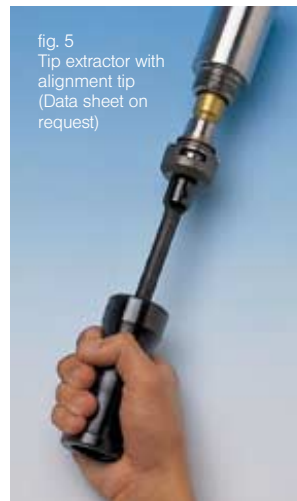

fig. 5
Tip extractor with alignment tip
(Data sheet on request)

Improved Measurement Techniques - the Basis of Optimal Nozzle Design

The basis for optimal design is the ability to accurately and precisely measure and analyse performance. LECHLER has developed the techniques to do this.

Using these techniques, reliable data on volume, pressure, impact force and droplet size can be acquired in the design phase of nozzles.

This data is used directly in the development process to optimize product design and manufacture.

Important factors in the design and evaluation of descaling nozzles are impact and distribution.

The LECHLER computer aided measuring system can represent this in three dimensions.

3D-diagrams enable us to represent the forces across the entire impact area.

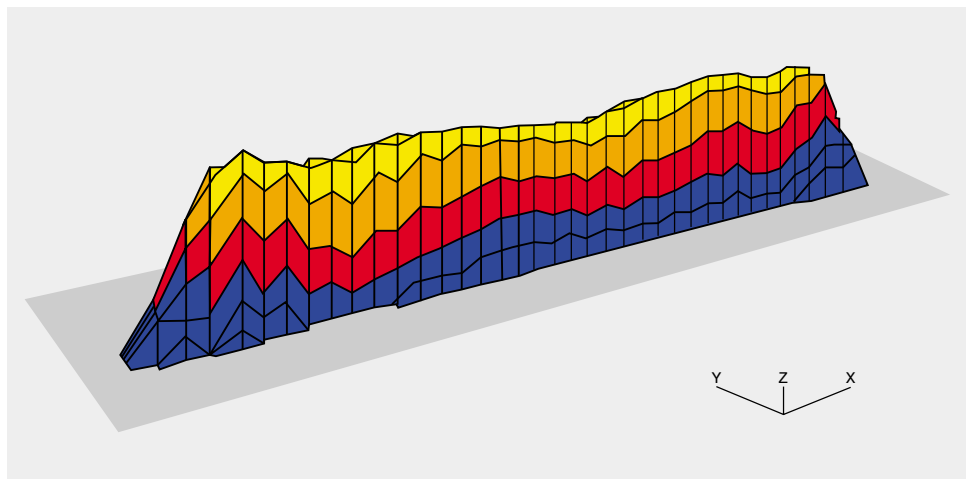

Three-dimensional representation of spray impact distribution

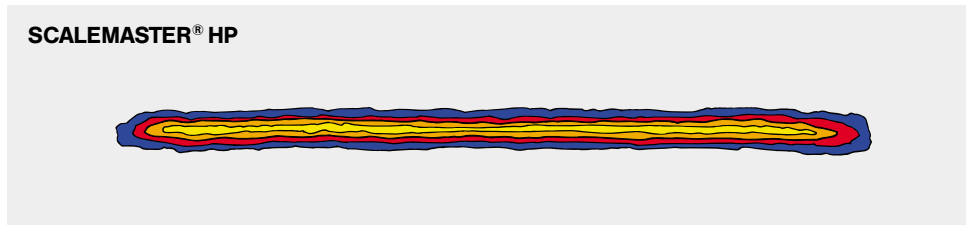

Footprint

Principal of operation for assessing Impact Force

LECHLER measures impact using a single point load cell which is traversed in a zig zag pattern through all areas of the spray, building up a precise image of all forces in the spray which are illustrated as a topographic view.

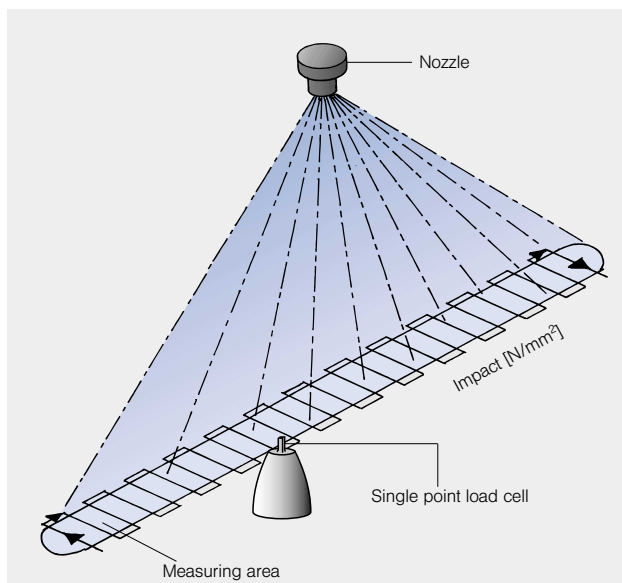

Measuring principle



Measuring device

Optimization of System Parameters with SCALEMASTER® HP

Optimising an existing system can be best achieved by targeting one of the three main design objectives (see diagram).

LECHLER will work with you to target the objectives at the beginning of an improvement project.

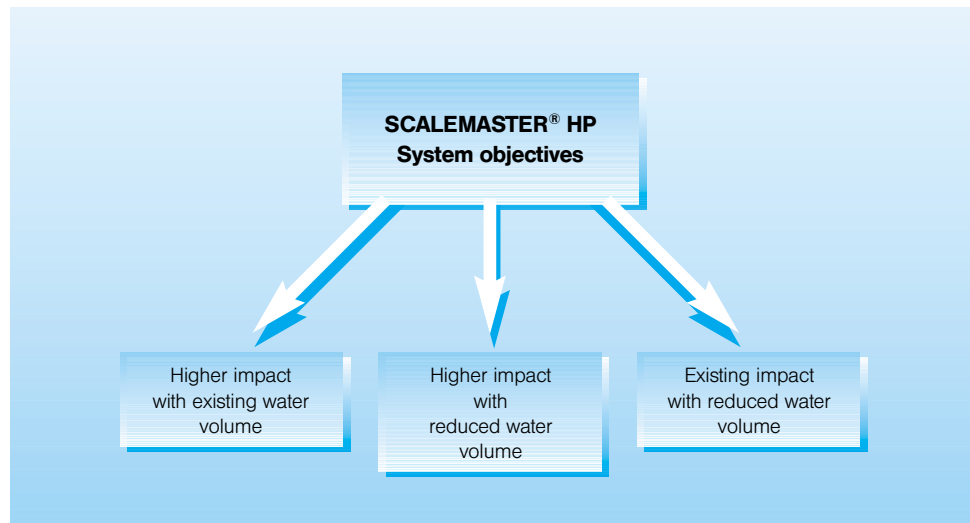

Nozzle arrangements

LECHLER utilizes its own inhouse developed software to produce proposals quickly and economically.

To receive a proposal from LECHLER, please complete the questionnaire at the back of this brochure and return it by telefax.

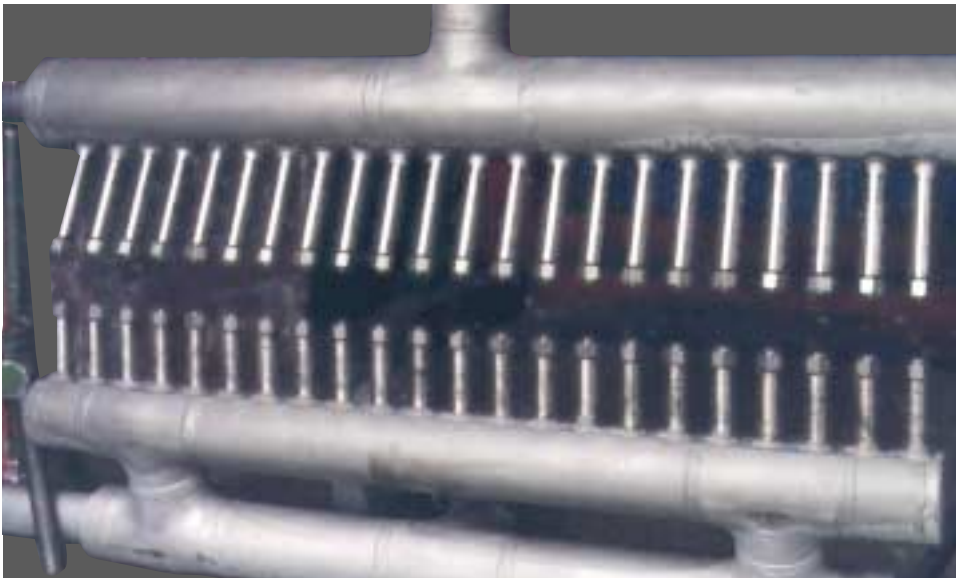
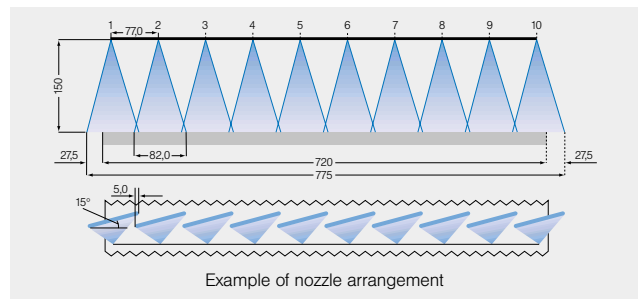

Lechler designs and manufactures complete descaling systems, and is pleased to place this expertise at your service.

Data Sheet for Nozzle Arrangement



Lechler GmbH
Precision Nozzles - Nozzle Systems
P.O. Box 13 23
72544 Metzingen / Germany
Phone: +49 (0) 71 23 962-0
Fax: +49 (0) 71 23 962-333

E-Mail: info@lechler.de
Internet: www.lechler.de

Company _____

Responsible _____

Address _____

Phone _____

Fax _____

E-mail _____

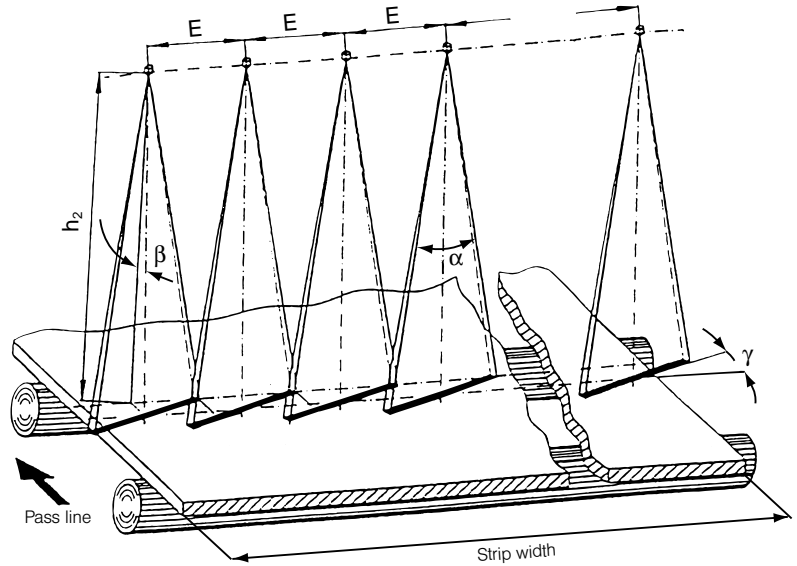

Questionnaire about existing Descaling Nozzle Arrangement

Name	Date	Department
Location of descaling installation: <input type="checkbox"/> Behind the furnace <input type="checkbox"/> RSB <input type="checkbox"/> FSB <input type="checkbox"/> Interstand descaling		
Format	Dimensions [mm]	Nozzle Data
Strip		top bottom
Slab		Number of headers
Plate		Nozzle type
Bloom		Horizontal distance (E) mm mm
Billet		Vertical spray height (h ₂) mm mm
Rounds		Spray angle (α) ° °
Material speed	m/s	Offset angle (γ) ° °
Pressure at header	bar	Impingement angle (β) ° °
Available max. water flow	l/min l/h	Room for sketch:

Lechler Ltd.
1 Fell Street, Newhall
Sheffield, S9 2TP
Great Britain
Phone: (01 14) 2 49 20 20
Fax: (01 14) 2 49 36 00
E-mail: info@lechler.com

Lechler Inc.
445 Kautz Road
St. Charles, IL. 60174
USA
Phone: (630) 377-6611
Fax: (630) 377-6657
E-mail:
GeneralMgr@lechlerUSA.com

Lechler France, S.A.
Immeuble CAP2 C51
66-72, Rue Marceau
93558 Montreuil, France
Phone: (1) 49 88 26 00
Fax: (1) 49 88 26 09
E-mail: info@lechler.fr

Lechler AB
Box 158
68324 Hagfors
Sweden
Phone: (46) 56 32 55 70
Fax: (46) 56 32 55 71
E-mail: info@lechler.se

Lechler S.A./N.V.
Avenue Mercatorlaan, 6
1300 Wavre, Belgium
Phone: (10) 22 50 22
Fax: (10) 24 39 01
E-mail: info@lechler.be

Lechler S.A.
Avda. Pirineos, 7
Edificio Inbisa
28700 San Sebastián de
los Reyes, Madrid - Spain
Phone: (34) 91 658 63 46
Fax: (34) 91 658 63 47
E-Mail: info@lechler.es

Lechler (India) Pvt. Ltd.
Plot # A-109 - Road # 18
Wagle Industrial Estate
Thane-400 604, India
Phone: (22) 25 81 11 96
Fax: (22) 25 82 12 62
E-mail:
lechler@lechlerindia.com