

ENGINEERING  
YOUR SPRAY SOLUTION



## Nozzles and Systems for the Metallurgical Industry



Steel

Non-ferrous  
metals

Aluminium

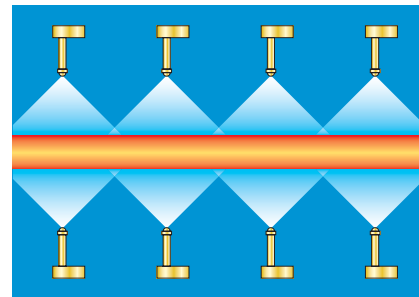
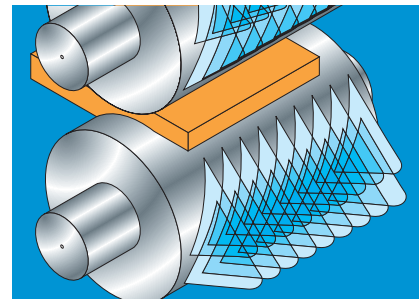
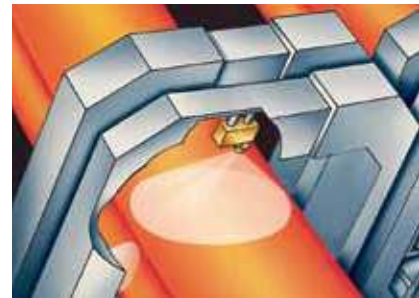

Lechler nozzles have been setting standards in quality, performance and design for over 125 years.

A wide range of specially developed and proven nozzles of many different designs and in a range of materials is available for applications throughout the processes of metal smelting, refining, casting, rolling and processing. You can also select from over 20,000 other Lechler nozzles for a very wide range of other applications – with new ones being added to the range daily!



Nozzle development



Commissioning and training by Lechler staff



# INDUSTRY

## A dynamic market with high expectations

Global steel production will increase dramatically in the years ahead. The globalization of the steel industry is not yet complete.



Every year, steel-making companies are being newly formed, with production plants on every continent. The trend is similar in the case of the aluminium industry and the producers of non-ferrous metals.

## The metallurgical industry places stringent demands on its suppliers

Most metallurgical plant and machine builders are already organized and active globally. Process optimizations, along with new technologies, enable production capacities to be permanently increased and the product quality of the metals produced to be further improved.

Nozzles and nozzle systems play an important role here in all production stages. The following basic requirements must be met for a successful partnership:

Great innovative strength in order to realize new technologies.

High problem-solving competence for ensuring plant availability.

Global organization as a guarantee of customer proximity and worldwide service.

Lechler meets these requirements in full.

## Wherever you are in the world, Lechler is close by and employs over 650 people

With production facilities in Germany, the USA, England, Hungary, India and China, sales offices in France, Spain, the BENELUX countries, Sweden and Finland, and representatives in over 25 countries, Lechler has a global network of service stations. This guarantees technical support for plant operators, a supply of spare parts and ongoing training of maintenance staff throughout the world.

## Everything is in Lechler's favor

### Leadership in technology

We use advanced design and production technologies.

### Process-related competence

combined with unsurpassed nozzle know-how allow us to find the optimum technical solutions.

### A worldwide service network

A supply of spare parts and technically competent after-sales service are guaranteed.

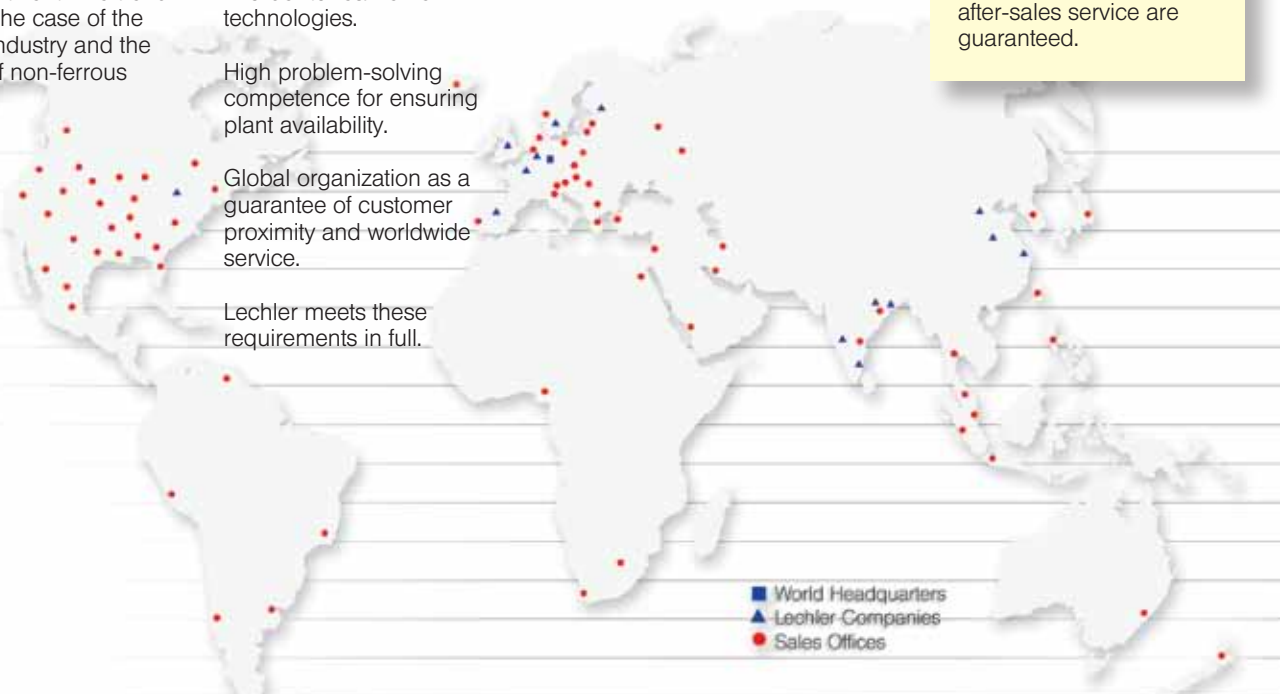

Headquarters, Germany



Lechler Ltd., United Kingdom



Lechler Inc., USA

# UNSURPASSED NOZZLE KNOW-HOW AND A WELL-FOUNDED KNOWLEDGE OF THE INDUSTRY

## The plant builder's partner

With innovative nozzle solutions, Lechler is always involved in the introduction of new technologies and also in the continuous further development of conventional processes.



## A well-founded knowledge of the industry

As an active member of many different national and international associations (VDMA, VDEH, AIST, S.E.A.I. & S.I., ATS and EUnited) and via numerous technical publications, Lechler has become very familiar with the subject matter.

Participation in EU research projects (RFCS) also has increasing Lechler's technological competence as its goal. Of course, you as our client also profit from this. Significant changes to operating conditions with regard to throughput capacity and the product quality demands of modern materials can arise over the course of the very long service lives of metallurgical machinery. Today the production of a wide range of material qualities also demands a much greater flexibility in the operating procedures and in maintenance. This is where existing plants often reach their limits.

**Besides the construction of new plants, one alternative can be the optimization of existing ones. The most common reasons for this are:**

- Identifying and remedying quality problems
- Improving ease of maintenance and lowering maintenance costs
- Increasing production speeds
- Changing the product formats and the material qualities (product mix)

In most cases, the decision involves a combination of the above reasons. It is therefore important for your needs to be clearly defined.

## Lechler nozzle configuration

An optimum nozzle configuration is the main prerequisite for fulfilling the production and quality specifications of all plants.

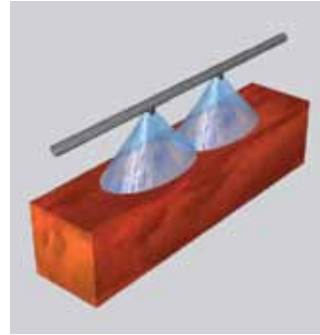

New nozzle solutions open up many different possibilities for saving costs. The optimization of nozzle systems can also make a significant contribution towards increasing production, quality and flexibility. With the help of Lechler's own PC-based simulation programs, we can analyze the current situation and make optimization suggestions based on state-of-the-art nozzle technology.

## Lechler system audits

Roll cooling in hot and cold rolling mills (steel, aluminium and non-ferrous) and also secondary cooling in continuous casting machines for steel are very complex systems and form part of the complete production processes. The full optimization potential can often be determined only via a precise study of all the important details. Lechler system audits include an evaluation of the existing production, performance and quality data, along with a carefully documented final report which, in addition to the collected and analyzed data, also contains suggestions for optimizing your system.

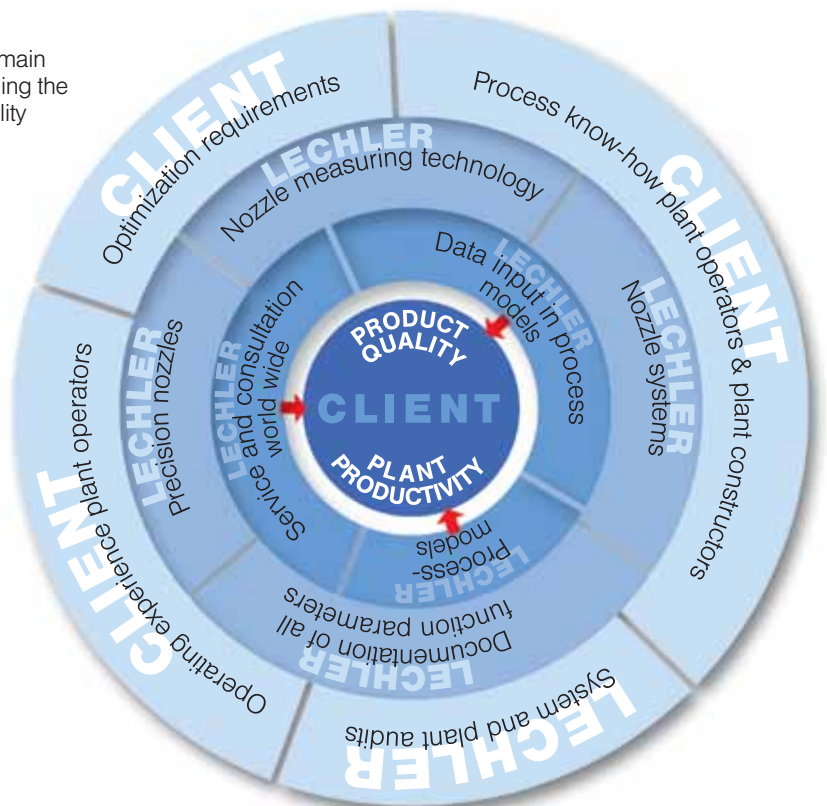

# SPECIAL NOZZLES AND SYSTEMS FOR EVERY FIELD OF APPLICATION



- Precision nozzles
- Nozzles and application systems
- Nozzle configurations
- Application software
- Computer simulation
- Nozzle measuring technology
- Plant audits and process optimization
- Maintenance and commissioning
- Training
- Spare part management
- Continuous casting of steel
- Hot and cold rolling of steel
- Hot and cold rolling of aluminium and non-ferrous metals
- Strip processing
- Other applications in metallurgical processes



# STATE-OF-THE-ART TECHNOLOGY TO ELIMINATE ALL RISKS

## Data and facts that you can rely on

There are many reasons for our product's success. A very important one is that based on precise measurements, we are able to make reliable statements about the spray characteristic of a nozzle. This provides reliable data for development, and also simplifies the evaluation for you with regard to fulfilling the exact purpose in the individual application – even before the nozzle has been integrated into your system. This saves time, reduces costs and ensures planning reliability.



We employ the latest methods to cover the entire measurement spectrum

- Flow rate
- Spray angle
- Spray shape
- Air flow measurement
- Droplet size measurement
- Droplet speed measurement
- 3D spray impact measurement
- Liquid distribution
- Spray videos
- Noise level measurement

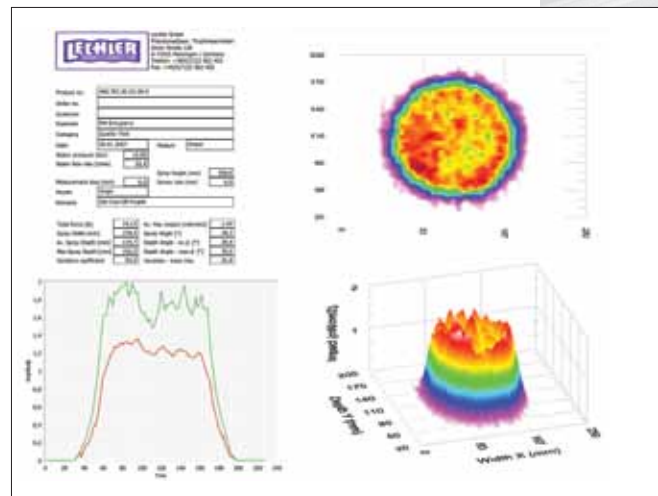

Documentation of a spray impact measurement

The performance data is determined with state-of-the-art measuring techniques and is documented accurately.

# SIMULATING AND SUCCESSFULLY OPTIMIZING PROCESSES

## Computer technology provides you with a glimpse into your plant's future

Lechler uses application software programs developed in-house in order to work out optimum solutions. This enables nozzle configurations to be simulated, analyzed and depicted.

Lechler configuration programs have also been used successfully for many years during the design of new plants. Nozzle data from Lechler measuring technology forms the basis here for reliable calculations that reflect reality.

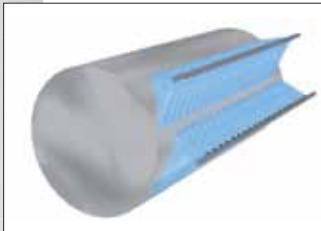

## Roll cooling, strip cooling and lubrication

Lechler has developed a special computer program for optimizing work roll cooling. The measured nozzle data and the installation conditions can be used to graphically depict (in the form of flow diagrams), analyze and improve the liquid distribution on the roll surface.

Strip cooling, cleaning and lubrication solutions can also be derived in this way.

## Solidification model for continuous casting machines

Lechler is a knowledgeable consultation partner with regard to questions relating to the optimization of nozzle configurations in continuous casting machines. We have developed a solidification model to establish benchmarking during a plant audit. On the basis of this and in line with the aims, it is then possible to investigate optimization potentials in detail.

## Lechler DESCALE

With the introduction of the SCALEMASTER® descaling nozzles in 1992, Lechler was the first nozzle manufacturer to develop and successfully use a configuration program. Since then, most descaling plants of the largest and most renowned plant builders have been designed and constructed with Lechler DESCALE software.

Hundreds of descaling spray headers throughout the world have been optimized in this way. In all cases, with this tool Lechler has also made a crucial contribution towards increasing surface quality and plant efficiencies.

Temperature profile of a continuous casting machine

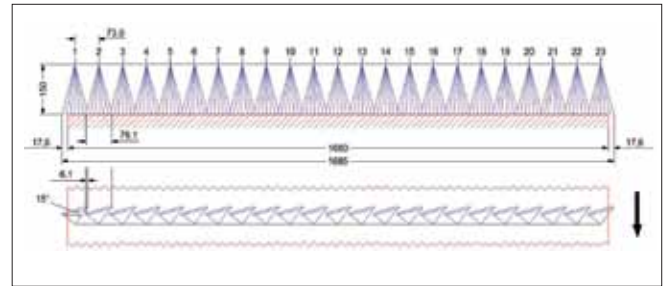
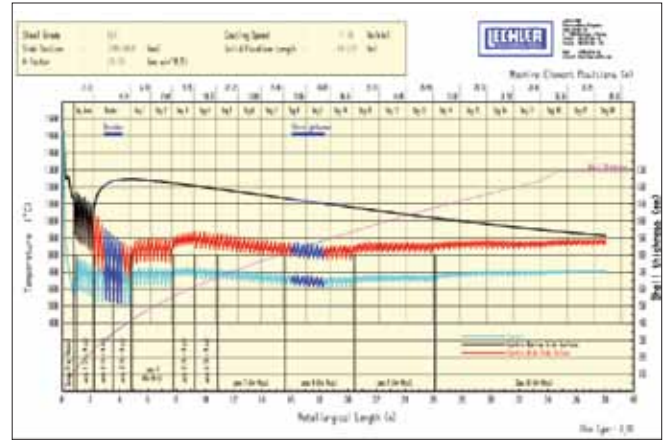

The Lechler DESCALE software optimizes the nozzle arrangement on a descaling spray header

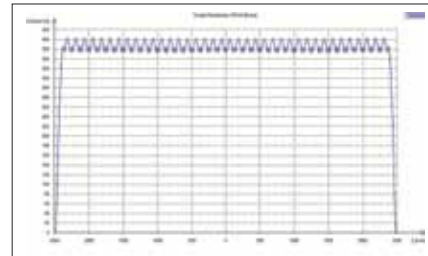

Liquid distribution for strip cooling

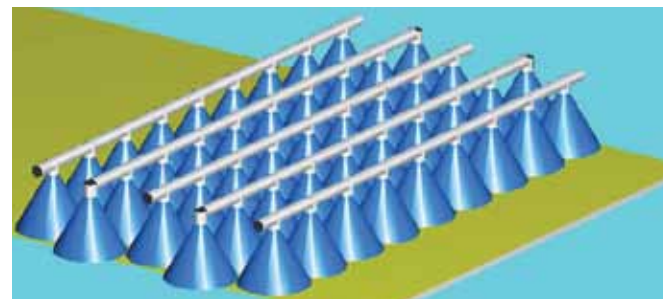

Visualization of the nozzle arrangement for strip cooling

# NOZZLES FOR OPTIMUM SECONDARY COOLING



**At Lechler, you will find the right solution for every plant**

It doesn't matter whether equipment for billet, bloom, slab or thin slab continuous casting machines is involved. The program ranges from standard single fluid nozzles for billet plants to more simple reinforced steels right through to special twin fluid nozzles (BilletCooler air mist nozzles) for plants in which very high-grade steels are cast for tire cord or seamless pipes.



Preparation of a measurement of the nozzle heat transfer coefficient



Liquid distribution measurement

Modern slab continuous casting plants are in most cases fitted with specially de-signed and customized air mist nozzles of the Master-cooler type. This applies to both conventional thick slab plants and the more compact thin slab plants.

## Single fluid nozzles

Lechler single-fluid nozzles with flat spray patterns or full cone nozzles are available with standardized flow rate and spray angle graduations. Rectangular nozzles produce a flat jet with a greater spray depth.

In addition to a standard program, variants of this nozzle family are designed especially for individual plants.

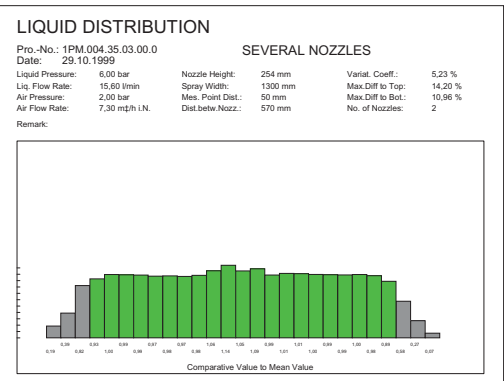

Documentation of a liquid distribution





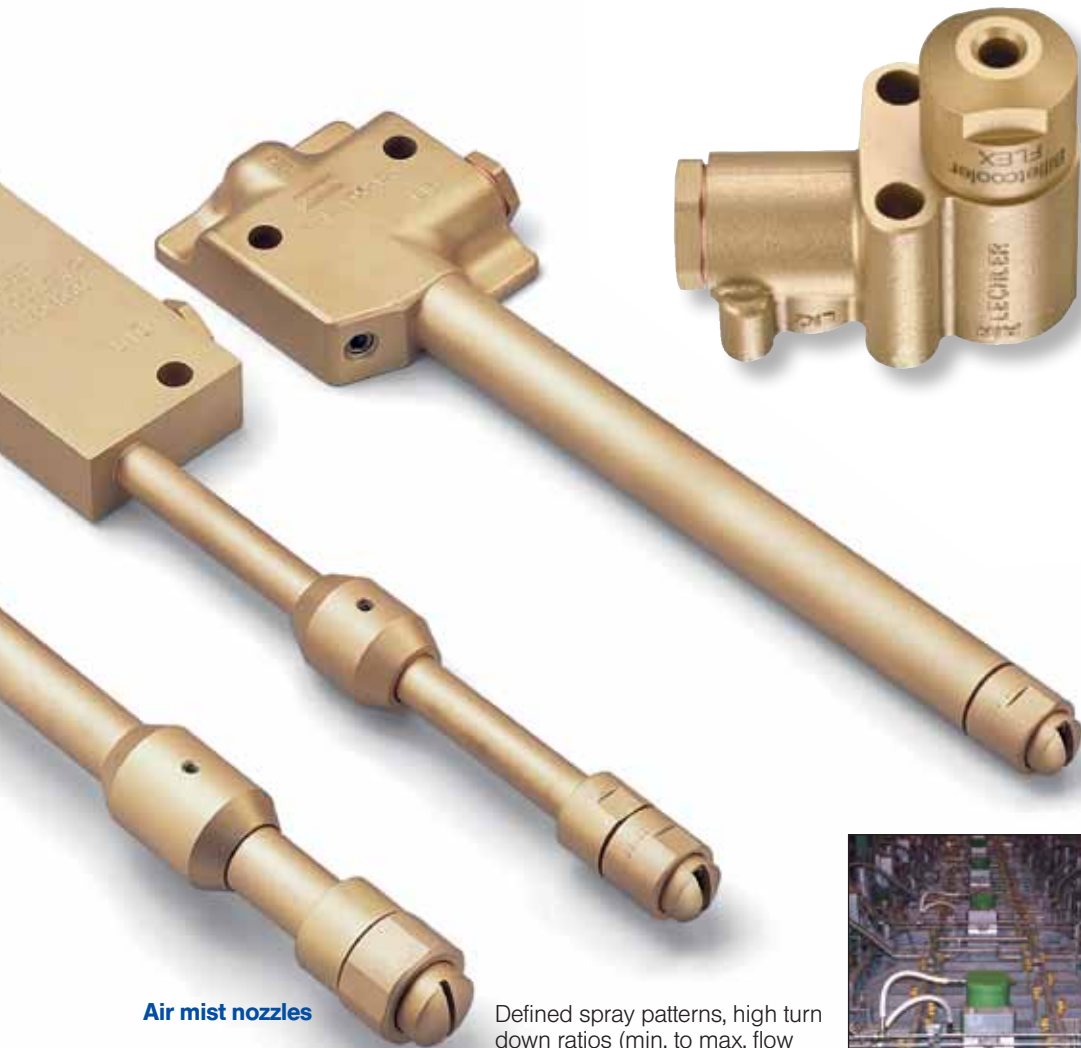

- Single-fluid nozzles with full cone, flat jet and rectangular spray patterns
- BilletCooler full cone air mist nozzles
- BilletCooler Oval air mist nozzles
- MasterCooler air mist nozzles
- Nozzle measuring technology and documentation
- Nozzle configurations
- Plant and system audits
- Conversion of the pipes and nozzle fittings of complete continuous casting segments
- Complete spray headers and spray rings

### Air mist nozzles

With the BilletCooler series, Lechler offers the world's first air mist nozzle for secondary cooling with a defined full cone. The Lechler BilletCooler Oval is the first air mist nozzle for secondary cooling with which a spray depth of up to 60l is possible with a non-clogging single slot orifice. This enables larger surface areas between the support rollers to be cooled more evenly. This in turn reduces the risk of strand cracking.

Air mist nozzles of the BilletCooler series should be used wherever the control range of single-fluid nozzles is no longer sufficient for the wide range of steel products in billet- or bloom casters, or when the nozzle's flow rate falls to well below 2 l/min. Standard programs with a full cone spray pattern and with an oval spray pattern with likewise standardized flow rate, spray angle and spray depth graduations are available.

Defined spray patterns, high turn down ratios (min. to max. flow rate) and very large free cross sections (not liable to clogging) are the stand-out features of BilletCoolers.

MasterCooler SMART® air mist nozzles are designed in line with the requirements of the secondary cooling system of each individual slab caster. The water flow rate, the spray angle, the liquid distribution, the turn down ratio, the pipe length, the pipe shape and the type of connection are all adapted here. To date, more than 100 slab strands have been successfully fitted with MasterCooler SMART® air mist nozzles.

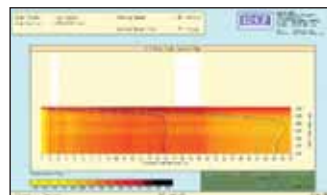

Strand temperature profile half width, total length



MasterCooler SMART in slab plant

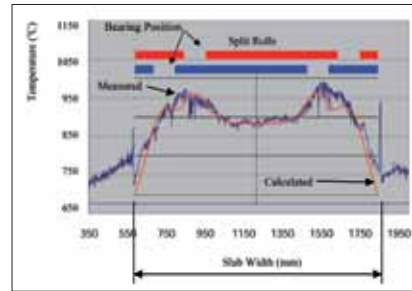

Temperature profile across strand, measured and calculated

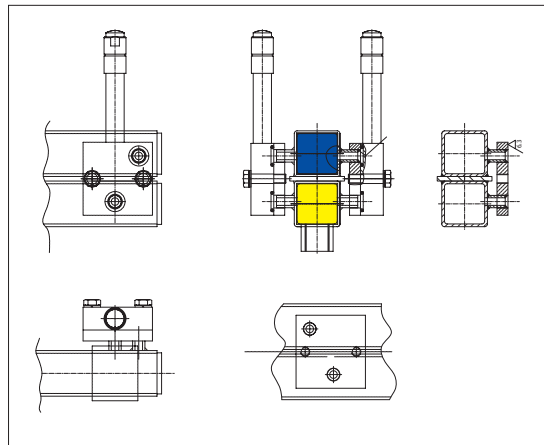

MasterCooler SMART installation

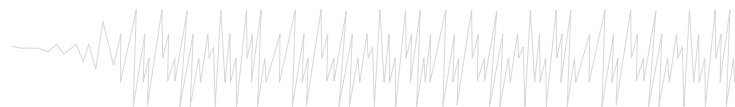

# NOZZLES FOR MORE EFFECTIVE DESCALING



**This is one of our specialty areas – hardly anyone knows more about this than we do**

When steel is hot-rolled, the quality of the rolled product surfaces depends significantly on effective descaling. The selection of the best descaling nozzles and their optimum arrangement is crucial here. Also, rising energy costs and ecological considerations are increasingly forcing rolling mill operators to define energy saving measures and to implement them.

The new **SCALEMASTER Superior**® from Lechler has immediately started to set new standards in this area. When this nozzle was developed, the use of computer-based design methods (CFD) enabled Lechler to largely eliminate internal liquid turbulences and pressure losses. This means that maximum impact increase can be achieved. Thanks to compatibility with earlier models, this allows even more effective descaling for the same energy input. In addition, it also opens up significant saving potentials due to reduced cooling of the rolled product by reducing the amount of water sprayed.

The use of new materials and the reduction in the number of individual components increase both service life and operational reliability – two more economic advantages. Nozzle configurations can be determined quickly and reliably thanks to the combination of measured values and calculation models in conjunction with the Lechler DESCAL configuration software. This ensures planning reliability and is one of the reasons why globally, several hundred descaling systems have been very successfully fitted with Lechler SCALEMASTER® nozzles.

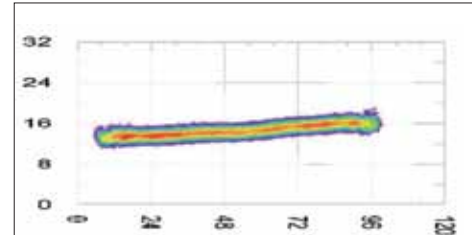

Descaling spray foot print protocol

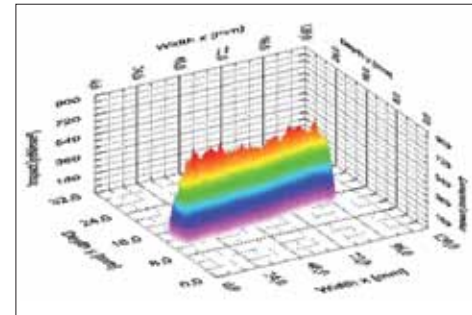

Three-dimensional representation of the impact distribution.



Stabilizer filter unit with optimized flow thanks to Computational Fluid Dynamics (CFD)

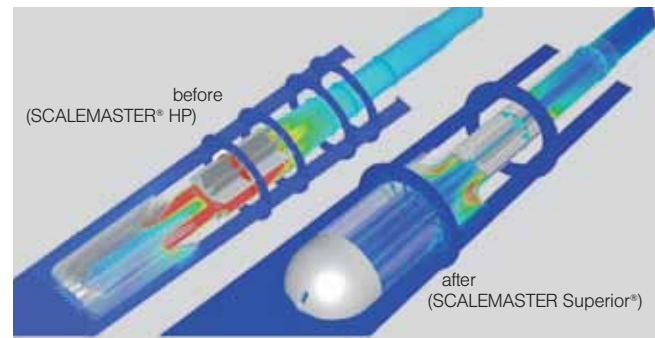

# PERFECT TECHNOLOGY FOR ROLL COOLING AND MUCH MORE



**Lechler has a solution for all other nozzle applications in hot rolling**

Only the optimal nozzle arrangements in roll cooling, for strip surface quenching (anti-peeling spray) in front of the roll bite or for interstand strip cooling guaranties a long service life of the work rolls and the required strip shape. Systems for strip surface in-spection, measurements of strip thickness gauge and shape deliver only reliable data if the strip surface is free of dirt and water. With nozzles from Lechler, very good results can be achieved here too.

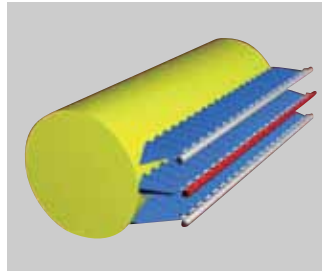

Roll cooling nozzle arrangement



Complete roll cooling spray header from Lechler

- Flat jet nozzles for roll cooling
- Flat jet and tongue nozzles for strip whipping in front of strip thickness gauge measuring units and surface inspection systems
- Nozzles for strip cooling in the run-out roller table
- Anti-peeling and interstand cooling nozzles
- WHISPERBLAST® air nozzles for blowing off strips in front of strip thickness gauges and surface inspection systems
- Studies and nozzle arrangement proposals
- Complete spray headers
- Application systems for the work roll lubrication (LSC)



# COLD ROLLING OF STEEL, HOT AND COLD ROLLING OF NOZZLES AND SYSTEMS FOR AND ECONOMY

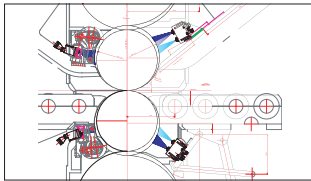

Selective roll cooling system, individually planned

**SELECTOSPRAY®** an indispensable actuator for shape control. It corrects reliably asymmetrical strip shape defects and supports work roll bending

To date, more than 230 Lechler SELECTOSPRAY® roll cooling systems have been installed globally in cold rolling mills for steel, aluminium and non-ferrous metals, as well as in aluminium hot rolling mills and foil mills. Profit from our comprehensive know-how in this specialist area.



Modulax and EVA -nozzle valves for every rolling mill

**SELECTOSPRAY®**  
**Nozzle valves**



Modulax-Superior valves

The new MODULAX Superior nozzle valve for electro-pneumatic control sets new standards with regard to operational reliability and plant availability, particularly for steel cold rolling mills and aluminium hot rolling mills. Zonings of 25 mm (Mini-Modulax S) and 50 mm are normal here.

The electrically controlled nozzle valves of the EVA series have proved to be optimally suited to aluminium cold rolling and foil rolling mills (50 mm zone division), as well as for rolling non-ferrous metals. 25 mm zone divisions are possible here too with the Mini EVA valve.

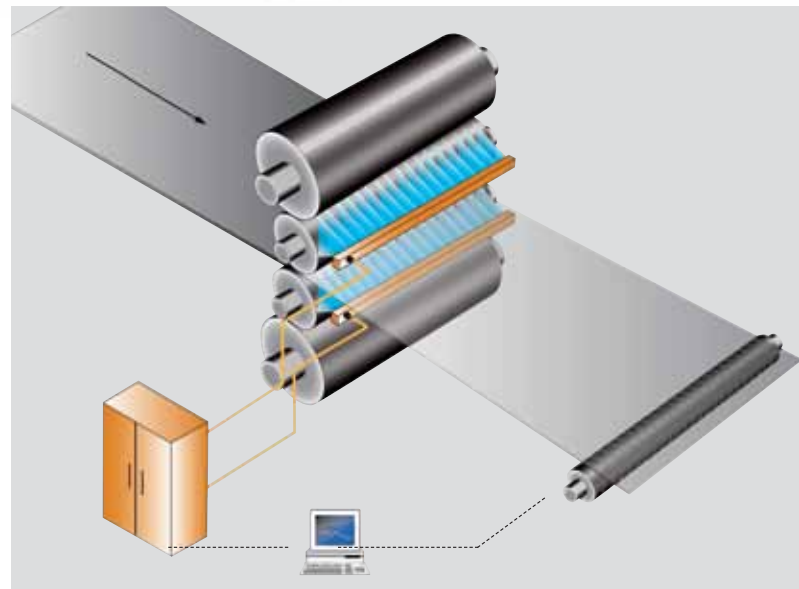

Electrically controlled SELECTOSPRAY® system with EVA valve technology. (25 mm/1", 50 mm/2")

Other valve concepts are available with the DSA series.

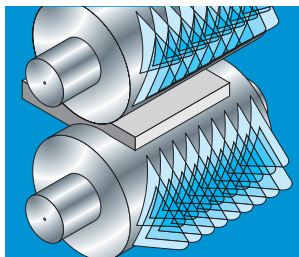

# INCREASING OF QUALITY



Optimum strip flatness thanks to simulation of the nozzle arrangement

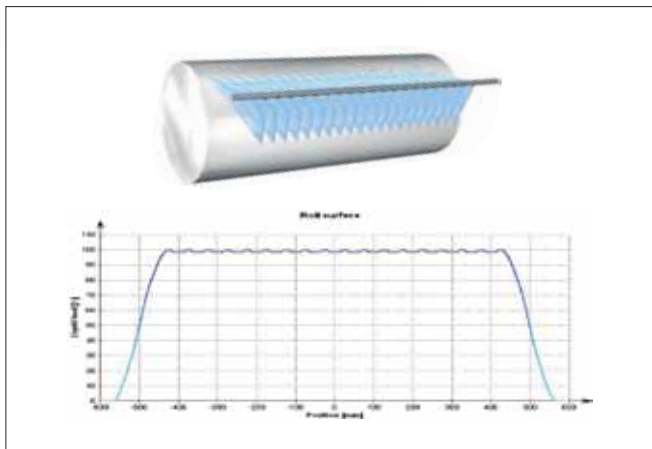

Control cabinet Selectospray system



The Lechler **SPRAY CONTROLLER LSC** for controlling automated spray processes is the ideal solution for the following applications:

- Direct application (strip lubrication) for cold rolling of tinplate
- Application of corrosion protection oils to strips
- Application of separating agents when doubling aluminium foils
- Application of wet temper agents
- Lubricating work roll gaps
- Application of lubricating oils in tension levelling machines for strips

The LSC system ensures reliable control over the process variables, combined with optimum and even application of the fluid. This allows product quality and productivity to be increased, and operating costs to be reduced.

- Flat jet nozzles for roll cooling
- Flat jet and full-cone nozzles for strip cooling
- Direct application systems for the strip lubrication (LSC)
- Application systems for strip oiling and lubrication (LSC)
- WHISPERBLAST® air nozzles for blowing off strips
- Selective roll cooling systems SELECTO-SPRAY® as an actuator for shape control
- Studies and audits of roll cooling in tandem lines
- Nozzle arrangement proposals
- Complete spray headers for optimizing the roll cooling



Mobile spray platform LSC

# VARIETY OPENS UP NEW POSSIBILITIES



**Lechler is the specialist company for nozzle and spray technology. Make use of the advantages of this wide product range**

of various materials such as PVDF, PTFE, polypropylene or stainless steel provide a broad basis for future-orientated and technically perfect solutions. WHISPERBLAST® air nozzles made of stainless steel or plastic are used for blowing off strips or strip edges.

Self-cleaning spray pipes (the "STAMM" system) allow nozzles and the pipe inner walls to be cleaned in a matter of seconds during operation. This is done either manually or automatically by rotating a cleaning brush inside the spray pipe. This prevents unscheduled and expensive plant shutdowns, and safeguards the product quality of the strip. If required, Lechler can also supply complete spray pipes made of polypropylene or PVDF for pickling lines. The optimization of the nozzle arrangement can be incorporated as a task at the same time.

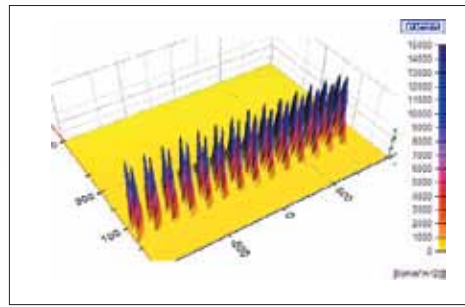

Liquid distribution of a nozzle arrangement



Self-cleaning "STAMM" spray pipe system

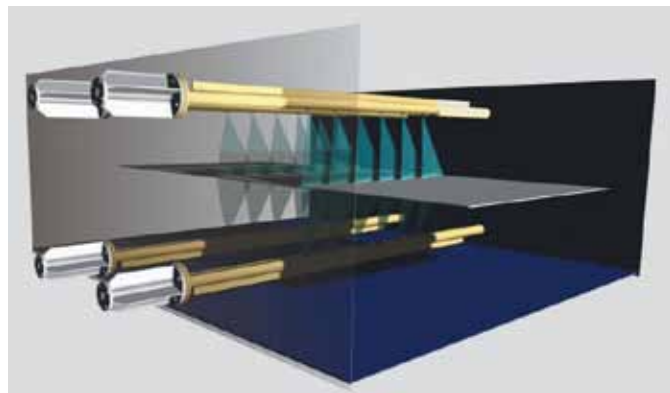

With Lechler nozzles, you can optimally fulfil all typical requirements on pickling, galvanizing and tinning lines, on strip coating lines, and on continuous annealing lines. These include cleaning and rinsing processes, but also the direct application of acids, for example. A wide range of standardised flat jet, tongue and full-cone nozzles made

Special Lechler hollow-cone nozzles made of oxide ceramic, silicon carbide, titanium and palladium-titanium are installed for regenerating acid in pickling lines after the spray-roasting process.



# OTHER NOZZLE AND SYSTEM APPLICATIONS

## Coke ovens

- Coke quenching
- Liquor flushing in the coke oven
- Cleaning the coke oven battery doors
- Gas cleaning and droplet separators

## Blast furnaces and sintering plants

- Combating dust and dust deposits on conveyor belts and transfer points
- External wall cooling
- Gas cleaning - gas cooling
- Gas cleaning in the slag granulation



## Steel production

- Electric furnace hood cooling
- Electrode cooling
- Cooling the outer skin of the converter
- Exhaust gas cooling and conditioning
- Dust suppression

## Continuous casting machines

- Flushing the scale channels
- Spraying off the slag during flame cutting
- Roller cooling
- Machine cooling
- Mold spray cooling



## Hot rolling

- Settlement of oxide dusts in the stand
- Intermediate stand cooling
- Strip surface quenching to protect the work rolls
- Strip spray-off and blow-off
- Blowing off heavy plates upstream of the levelling machine
- Crop shears blade cooling in pendulum shears
- Ultra fast cooling / quenching of plates and strips
- Strip cooling in the run-out roller table
- Rolled product cooling on the cooling bed



## Forging and pipe production

- Mandrel bar and tow bar cooling and lubrication
- Descaling forged pieces
- Roll cooling in railway wheel manufacture



## Other applications

- Gear lubrication
- Pickling and flushing steel wire in pickling plants



**ENGINEERING  
YOUR SPRAY SOLUTION**



## LECHLER WORLD-WIDE



Edition 9/16 • USA • Subject to technical modification

### **Lechler, Inc. • Precision Nozzles • Nozzle Systems**

**445 Kautz Road, St. Charles, IL 60174 • Phone (800) 777-2926 • Fax (630) 377-6657 • [info@LechlerUSA.com](mailto:info@LechlerUSA.com) • [www.LechlerUSA.com](http://www.LechlerUSA.com)**

**Belgium:** Lechler S.A./N.V. • Avenue Mercatorlaan, 6 • 1300 Wavre • Phone: +32 10 225022 • Fax: +32 10 243901 • [info@lechler.be](mailto:info@lechler.be)

**China:** Lechler Intl. Trad. Co. Ltd. • Beijing • Rm. 418 Landmark Tower • No. 8 Dong San Huan Bei Lu • Phone: +86 10 84537968, Fax: +86 10 84537458 • [info@lechler.com.cn](mailto:info@lechler.com.cn)

**Finland:** Lechler Oy • Jäspilänkatu 18 • 04360 Kerava • Phone: +358 207 856880 • Fax: +358 207 856881 • [info@lechler.fi](mailto:info@lechler.fi)

**France:** Lechler France, S.A. • Bât. CAP2 • 66-72, Rue Marceau • 93558 Montreuil cedex • Phone: +33 1 49882600 • Fax: +33 1 49882609 • [info@lechler.fr](mailto:info@lechler.fr)

**Germany:** Lechler GmbH • PO Box 13 23 • 72544 Metzingen • Phone: +49 7123 962-0 • Fax: (49) 7123 962-444 • [info@lechler.de](mailto:info@lechler.de)

**Great Britain:** Lechler Ltd. • 1 Fell Street, Newhall • Sheffield, S9 2TP • Phone: +44 114 2492020 • Fax: +44 114 2493600 • [info@lechler.com](mailto:info@lechler.com)

**India:** Lechler (India) Pvt. Ltd. • Plot B-2 • Main Road • Wagle Industrial Estate • Thane (W) • 400604 • Phone: +91 22 40634444 • Fax: +91 22 40634497 • [lechler@lechlerindia.com](mailto:lechler@lechlerindia.com)

**Italy:** Lechler Spray Technology S.r.l. • Via Don Dossetti, 2 • 20080 Carpiano (Mi) • Phone: +39 02 98859027 • Fax: +39 02 9815647 • [info@lechleritalia.com](mailto:info@lechleritalia.com)

**Sweden:** Lechler AB • Kungsängsvägen 31 B • 753 23 Uppsala • Phone: +46 54 137030 • Fax: +46 54 137031 • [info@lechler.se](mailto:info@lechler.se)

**Spain:** Lechler S.A. • Avda. Pirineos 7 • Oficina B7, Edificio Inbisa I • 28700 San Sebastián de los Reyes, Madrid • Phone: +34 91 6586346 • Fax: +34 91 6586347 • [info@lechler.es](mailto:info@lechler.es)