



Tongue-type nozzles with dovetail and captive cap nut

Series 686. XXX.WW.09



Wide, sharply defined flat fan pattern.
Non-clogging.
Automatic jet alignment due to dovetail guide.
Captive cap nut for easy maintenance.

Applications:
 Pickling, rinsing.

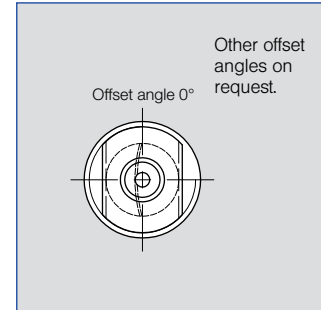
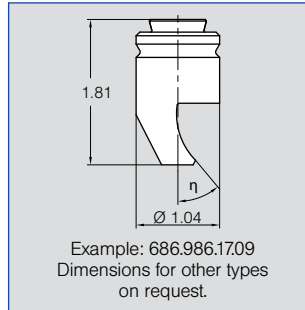

Spray angle	η	Ordering no.		Orifice diameter [in]	Flow Rate (Gallons Per Minute)			Spray width B at p=30 psi H=10"
		Type	Mat. no. 17 ¹ AISI 316Ti/ AISI 316L		14.5 psi	liters per minute	72.5 psi	
90°	40°	686. 646	○	.087	0.75	4.0	1.7	21
		686. 686	○	.087	0.94	5.0	2.1	21
		686. 726	○	.094	1.2	6.3	2.6	21
		686. 766	○	.106	1.5	8.0	3.3	21
		686. 806	○	.118	1.9	10.0	4.2	21
		686. 846	○	.134	2.3	12.5	5.2	21
		686. 886	○	.150	3.0	16.0	6.7	21
		686. 926	○	.165	3.7	20.0	8.4	21
		686. 966	○	.185	4.7	25.0	10.4	21
686. 986	○	.209	5.2	28.0	11.7	21		
140°	75°	686. 648	○	.220	.75	4.0	1.7	54
		686. 688	○	.087	.94	5.0	2.1	54
		686. 728	○	.094	1.2	6.3	2.6	54
		686. 768	○	.106	1.5	8.0	3.3	54
		686. 808	○	.118	1.9	10.0	4.2	54
		686. 828	○	.134	2.1	11.2	4.7	54
		686. 848	○	.142	2.3	12.5	5.2	54
		686. 888	○	.150	3.0	16.0	6.7	54
		686. 908	○	.165	3.4	18.0	7.6	54
		686. 928	○	.177	3.7	20.0	8.3	54
		686. 948	○	.185	4.2	22.4	9.4	54
		686. 968	○	.193	4.7	25.0	10.4	54
		686. 988	○	.209	5.2	28.0	11.7	54

¹We reserve the right to deliver AISI 316Ti or AISI 316L under the material no. 17.

Other types and materials on request.

Example **Type** + **Material no.** + **Code** = **Ordering no.**
of ordering: **686. 646** + **17** + **09** = **686. 646. 17. 09**

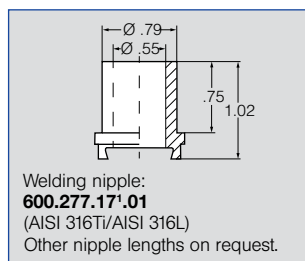
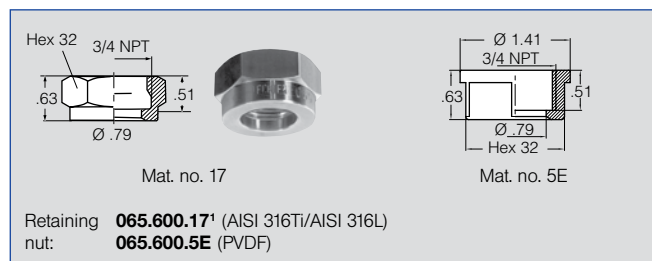

¹We reserve the right to deliver AISI 316Ti or AISI 316L under the material no. 17.

Welding nipples and cap nuts must be ordered separately. Please see pages 44 and 45 for suitable accessories.

Conversion formula for the above series: $V_2 = V_1 \sqrt{\frac{P_2}{P_1}}$