

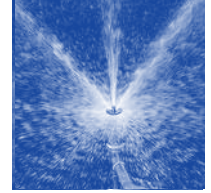

Pop-up foam extinguishing nozzle Series 500.447.B2.40





The pop-up foam extinguishing nozzle meets customer-specific requirements for fire protection on landing decks. However, rotation of the three central extinguishing jets is omitted on this nozzle. This simplifies the design and makes the nozzle an inexpensive alternative for hangars, for example.

Material:

Seawater-resistant 316LN SS

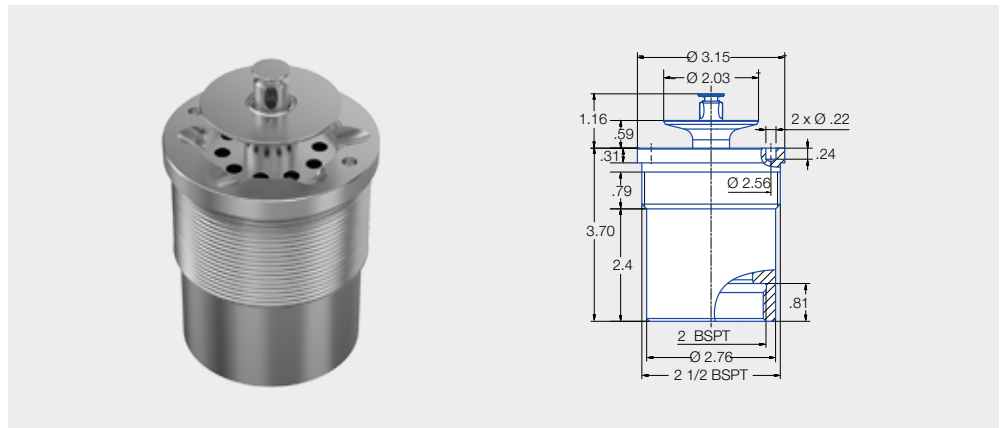
- Spray circle diameter: up to 29.5 ft
- Spray height: up to 16.4 ft
- Recommended operating pressure: 72-116 psi
- Integrated emergency operation characteristics



Spray angle 	Ordering no.	E Ø [in]	Flow Rate (Gallons Per Minute)				K-factor
	Type		45	60	75	90	
180°	500.447.B2.40	.14	96.95	108.31	128.12	137.11	183

E = narrowest free cross section