



Chemical Industry Application Notes

Engineering to help you optimize nozzle applications

Preventing contamination: Nozzles in the product pathway

1



There are frequent situations where a nozzle, especially a tank washing device, is mounted in process equipment where it can come into contact with product or feedstocks. That nozzle could become a source of contamination, but it does not have to if you follow some basic practices that will minimize such problems.

The easiest example to consider is a tank washing nozzle mounted inside a tank. If it's part of a CIP system or left in the tank for accessibility reasons, it probably stays in place through all product cycles. During cleaning periods, it sprays washing chemicals and rinses. While the system is operating, it can be splashed with product or even immersed completely. The key is to keep it from accumulating materials that could ultimately become contaminants.

Depending on your products, you must determine how easily they can be contaminated. For illustration purposes, let's look at an extreme case common to the

pharmaceutical or food industry. They have developed specific protocols for handling these situations which you might find very informative.

Illustration 1 shows a tank washer in a tank where it is immersed in the product. Just a few minutes ago, it could have been spraying a bactericide which we don't want mixed with the current contents.

Illustration 2 shows a close-up of the tank washer designed specifically to work in critical situations. Here are some of the features it has to minimize contamination potential. Some points are designed especially to eliminate any pockets or areas where bacteria or mold can grow.

Inlet—The nozzle attaches to the feed pipe using a pin but no threads. This fitting allows a portion of the sprayed liquid to escape through the neck and around the pin. This flushes the connection and makes sure no material builds up in that area. Threaded inlets are not

2

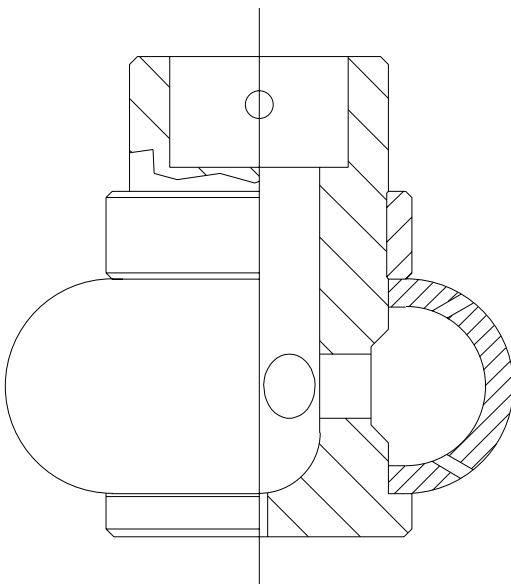

normally allowed in sanitary applications.

Self Draining—When mounted vertically, the unit is designed with internal channels and holes that will allow all the liquid to drain by gravity alone. When combined with properly installed piping (see our last issue) all the liquid used will drain from the pipe and nozzle with no dead areas where it can accumulate.

Self Flushing—While the nozzle is spraying, all the moving parts are lubricated and flushed with the liquid. This keeps the internal sections from trapping any deposits.

Surface Finish—All internal and external surfaces are very smooth and free from pockets or crevices. Even internal corners have a radius. Any places where contamination could accumulate need to be minimized.

Material—The actual material of construction has to be appropriate for the application and one that does not contribute to the development of contaminants.

These concepts cover many of the requirements for such critical applications and apply to nozzles for other applications as well. In some cases specific feedstocks

may be added through a fixed nozzle. The same points could apply to that.

For your particular application, you need to determine how critical each element is. If contamination is not very likely, you may be able to relax some of the issues.

One of the best documents on the topic is available from IAFIS, who administers the 3-A Sanitary Standards Program.* Their document “3-A Sanitary Standards for Spray Cleaning Devices to Remain in Place, No. 78-00,” is one of the most concise guides for high sanitation applications available.

Lechler manufactures tank washing nozzles that have been granted the 3-A® Symbol for use in strict sanitary environments such as dairy and food manufacturing. These tank washers meet the requirements of 3-A Standard 78-00. These nozzles, when used in conjunction with appropriate mounting, piping and operational practices, provide the means to deliver reliable cleaning with minimal contamination potential.

**IAFIS; 1401 Dolley Madison Blvd; McLean, VA 22101 703-761-2600 or www.3-A.org*

Nozzle layout for headers, Part 1: Keep the liquid distribution consistent

In many cases, covering an area with spray requires more than one nozzle. If so, you should start to give the nozzle positions some thought using a few simple guidelines.

There are two main approaches: Full cone and flat fan arrays. Each has its purpose and primary applications. In this issue we'll discuss the latter. You'll have to wait for the discussion of full cones.

Flat fan headers

When the object is to wash a moving target, a flat fan header is typically the first choice. These include:

- Washing a product on a conveyor.
- Washing the conveyor belt itself.
- Rinsing cake on a filter belt.
- Spraying a web or large sheet.

The common element is that the product is moving past the nozzles and a narrow spray line (sort of a curtain) is desirable. The typical configuration is a group of flat fan nozzles arranged on a header pipe positioned across the target. While this is not a difficult setup, a few moments of analysis can help you determine the nozzle selection and arrangement to keep the liquid and impact distribution even across the full width.

When making the design, there are several elements to consider:

Flow rate and pressure—Your process and available equipment will decide these parameters. Ultimately the total flow will have to be divided among the number of nozzles selected.

Header position—Frequently the final location of the header is determined by equipment constraints. There is only so much space and you have to work within that. Otherwise, if you have a choice, the height can be an element you use to optimize the process.

At this point, look at the spray overlap diagram. This illustration makes a few assumptions:

Many flat fan nozzle designs have “tapered” or “parabolic” distribution. It means that more of the spray is concentrated in the middle of the fan than the edges. This is deliberate and for just this type of application. (Lechler's catalog indicates which of our product lines have this feature. With other manufacturers you may have to ask.) The idea is that when the sprays are overlapped by 30%, the liquid will be distributed evenly across the full width.

The sprays need to be offset slightly so the droplets do not

Next issue: Full cone header designs, including layouts for spray distribution on to packing and mist eliminators.

collide in mid air. Since they are coming from different directions, providing a little extra space allows them to follow their path without impinging on each other.

That in mind, look at the two examples. Both have the header in the same position (8" above the target) and use the 30% overlap suggested. Both have the same combined flow rate and operate at the same pressure (10 gpm at 40 psi), but the effect of the two will be different. Here are the details:

Example A uses 17 nozzles (632.512.16.BC; .59 gpm at 40 psi, 25° spray angle) spaced 2.45" apart. This is a large number of small capacity narrow angle sprays.

Example B uses 5 nozzles (632.726.16.BC; 1.95 gpm at 40 psi, 80° spray angle) spaced 9.10" apart. This is a smaller number of larger capacity wide angle sprays.

Header A would cost more and be more work with 12 more mounts to fabricate, so why would somebody do that? It depends on what the spray is supposed to do. While both headers would distribute the liquid evenly, **A** would also distribute the impact much more evenly. Look at the vectors of the droplets on **A**. They are much more perpendicular to the surface they strike.

With **B**, the impact is concentrated directly below each nozzle in 5 bands across the spray width. Contrast that with the areas where the nozzles overlap. There the droplets are hitting at almost a 45° angle after traveling a longer path from the nozzle. The impact would be much lower. However, if impact uniformity is not the concern, this would be a more economical choice. Additionally, by using larger capacity nozzles, **B** would be harder to clog.

The key is determining which characteristics are most important to you. Impact? Header simplicity? Clog resistance? Mounting constraints? Fortunately, Lechler offers a wide enough line of flat fan nozzle capacities and configurations to handle just about any job. Ask for a copy of our latest catalog if you don't have one. What's more, we can design and fabricate custom headers for your application. Let us know the details of your application, and we will design it to maximize the effectiveness you're looking for.

Making calculations such as this is easier with our Spray Nozzle Calculator. This FREE handy slide chart is available at your request. See the back page for details.

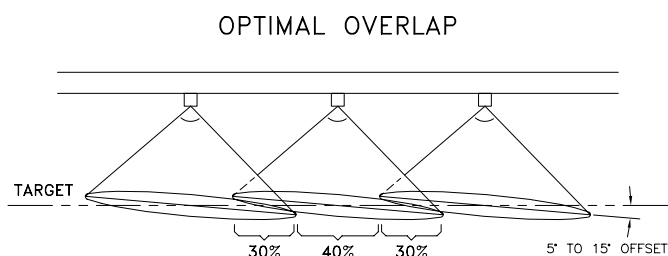

Example A

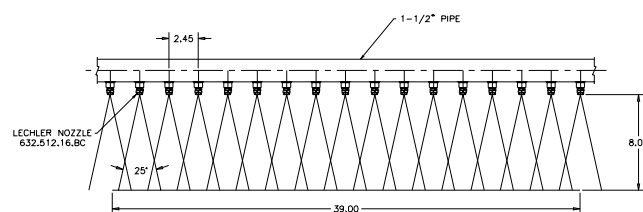

Example B

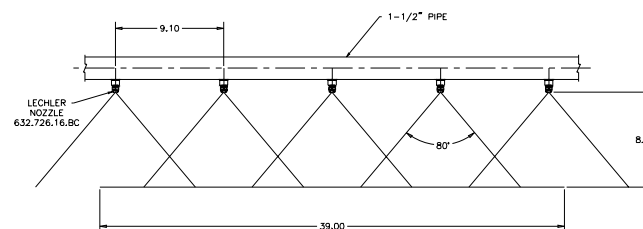

Come see us in Houston



PROCESS INDUSTRIES EXPOSITION

Booth 1318

Lechler will be exhibiting at the Process Industries Expo, April 24-26, George R. Brown Convention Center, Houston, Texas. Call for information.

FREE Spray Nozzle Calculator

Ask for one of our handy calculators. It can help you make many quick calculations and conversions related to spray nozzles and liquid flow:

- Spray coverage vs. distance
- Flow rate vs. pressure
- PSI vs. bar
- Gallons vs. liters
- Pipe flow and sizing

Check the box below and get your copy!



Do you want future issues of this newsletter?

You probably don't think about nozzles every day. Unless you work for a company like ours, there are other things on your mind. But, when the topic comes up, you need to know where to turn for help. These papers contain technical information, application tips and ideas for nozzle applications specifically for the chemical and pharmaceutical industries.

If you want future issues (four each year) and our most current catalog information, fax this page back to us with the YES box checked. If there is someone else who might like it, send his or her name too. Make sure we can read your address label.

If you don't, check the NO box. It will save paper, printing and postage if you aren't really interested.

- YES, send me future issues.
- Send me a FREE Spray Nozzle Calculator
- Send me your previous issue too. I missed it.
- Send me your latest catalog.

Additionally, please send information to:

- NO, I really don't need it.



Lechler Inc.
445 Kautz Road
St. Charles, IL 60174

1-800-777-2926
Fax 1-800-444-7069

Contact us by email:
ChemicalApps@LechlerUSA.com
www.Lechler.com

PRSR STD
U.S. POSTAGE
PAID
CAROL STREAM, IL
PERMIT NO. 475