

# **USER BENEFITS OF MODERN AIR MIST NOZZLE AND SECONDARY COOLING SYSTEM TECHNOLOGY**

Jürgen W. Frick  
Lechler GmbH & Co KG  
Ulmer Strasse 128  
D-72555 Metzingen  
Germany  
Tel.: ++49-7123-962-401  
Fax : ++49-7123-962-333  
E-mail : [frju@lechler.de](mailto:frju@lechler.de)

Key Words : Heat transfer coefficient (HTC), air-water ratio, turn-down ratio, water distribution, air mist nozzle, flow rate, pressure, header pipe

## **INTRODUCTION**

The demand for improved product quality and increased productivity has focussed attention on the need for more efficient systems of spray cooling during continuous casting. Nozzle characteristics must be investigated and test procedures developed to measure cooling patterns and heat transfer. Improved nozzle design and air/water systems gives in better water distribution and this reduces surface defects, corner cracking and core segregation. There are also important operational benefits which enable expansion in the product mix and production capacity.

Of particular concern are :

- Nozzle type selection according to the product mix and machine design
- Heat transfer coefficients measurements of the spray nozzles
- Air-water ratio
- Water turn-down ratio
- Water distribution
- New methods of nozzle mounting and new header pipe designs
- New air mist nozzles for long product casting

This paper focuses on these seven points in connection with new nozzle types and revolutionary new on board segment pipe designs

## **NOZZLE SELECTION ACCORDING TO MACHINE DESIGN AND PRODUCT MIX**

Unlike in the early days the layout of the secondary spray cooling system is one of the first steps when a new continuous casting machine is designed or when an existing machine undergoes a major revamping. However, the determination of the strand surface and internal temperature distribution along the metallurgical length of the machine comes first. This is followed by the application of a thermo-mathematical computer model for the calculation of the heat transfer coefficient (HTC) distribution for each steel grade and product dimension. The spray nozzle sizes (flow rates) for every cooling zone are established in the next step. The use of mathematical models which are based on actual HTC measurements of spray nozzles help to determine the exact nozzle specification including details such as min. and max.

water flows, nozzle pitches, spray heights and nozzle overlaps. An understanding of the cause of strand defects also influences the specification of the spray nozzle parameters.

Only in a second phase the mechanical design of the machine segments can follow. This practise underlines the significant effect which the spray nozzle arrangement in general and the nozzle design in particular have on the quality of the continuously cast products.

A defect free slab, bloom, billet or beam blank and an economical operation are the objectives to be achieved by the spray nozzle cooling system. The nozzle manufacturer must have detailed knowledge of the behavior of the nozzles under operation conditions and the machine segment design.

### SPRAY NOZZLE HEAT TRANSFER COEFFICIENT (HTCs) MEASUREMENTS

In order to select the correct spray nozzles for every machine position the HTCs of the spray nozzles have to be measured. One method to measure the HTCs of spray nozzles is the ‘moving nozzles’ test which is shown in Figure 1. A steel plate with 24 thermocouples, embedded at a depth of 2.5 mm, is heated to a temperature of, for example, 1200°C in an atmosphere of inert gas.

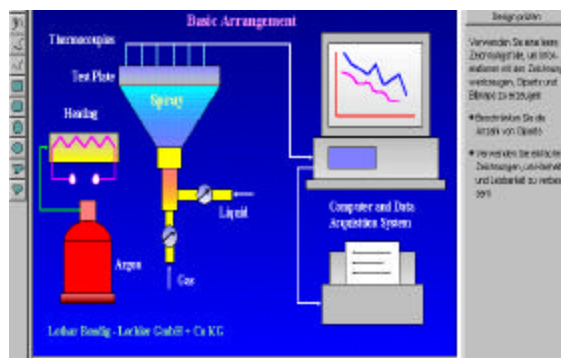

Fig.1: Scheme of the “Moving Nozzle” HTC measuring facility

The top surface of the plate is isolated whereas the bottom side is cooled by the nozzle to be tested. The nozzle in the manifold is placed in a movable arm so that the nozzle moves parallel to the plate by means of a computer controlled electric motor.

To simulate movement of the strand from one roller gap to another, the computer actuates the removal of a deflector plate in order to start the cooling process. The nozzle then moves from left to right with the deflector open and then in the opposite direction with the deflector closed. The dark strip on the hot plate shown in Figure 2 is the area where the spray impinges from the bottom side. The temperature of the water and the plate are measured simultaneously until the plate attains the same temperature as that of the water

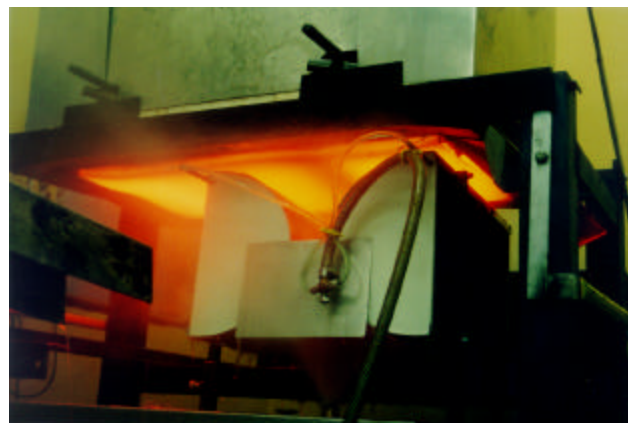

Fig. 2: Photo of the “Moving Nozzle” HTC measurement facility

The temperature history records and information on the nozzle position in relation to the plate are stored in a data logger. These data are then used as for evaluating the heat transfer conditions and for computation of HTCs.

### AIR-WATER RATIO

A higher water flow is not the only factor decisive for the heat transfer coefficient as mentioned above. The nozzle spray angle and spray height are playing an important role, too. Both determine the spray foot print (width and depth of spray) and are therefore, factors of the water jet density (water flux) and the jet impact. Besides these two variables the ratio between the compressed air volume and the water flow must be considered as another important factor in the secondary cooling process. Spray cooling on the strand involves boiling and the formation of a steam layer on top of the steel surface. The compressed air is providing the kinetic energy necessary for penetration of the droplets through this steam layer. In one slab caster break outs often occurred in the top zone which led to an investigations of spray nozzle HTCs under actual operation conditions, Figure 3.

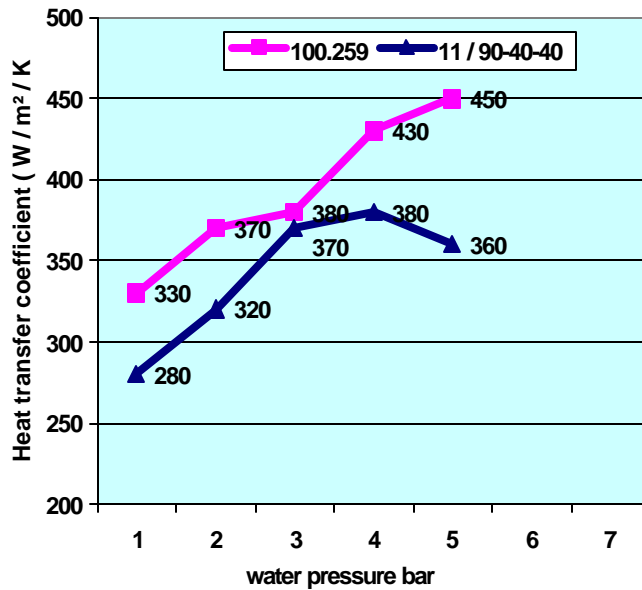

Fig. 3: HTC diagram of nozzle types 100.259 and 11/90-40-40, p-water 1,0 to 5,5 bars, p-air 2bars constant

In order to understand the HTC curves of Figure 4 a combined air and water flow diagram has also been established, Figure 4.

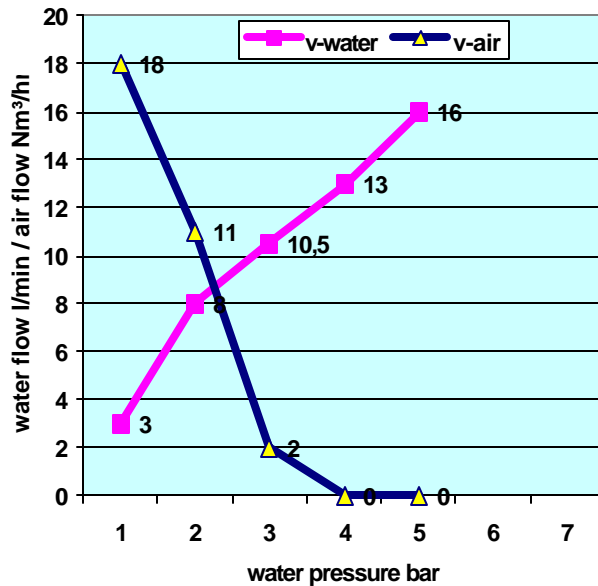

Fig. 4: Air-water flow diagram nozzle type 11 / 90-40-40, p-water 1,0 to 5,5bars, p-air 2bars constant

As expected the drop in HTC beyond 4 bars water pressure can directly be attributed to the fact that the nozzle type 11/90-40-40 consumes almost no compressed air any more at water pressures above 4 bars. The installation of a modern air mist nozzle type 100.259, providing the required air volume for an effective cooling up to the maximum water pressure (5,5bars in this case), led to a stable operation eliminating the break out problem, especially in summer when the cooling water temperature is significantly higher. This tailored nozzle was designed to reach the highest HTC at the maximum water pressure of 5,5bars. The HTC value of an air mist nozzle which is not supplied with a sufficient amount of compressed air can not reach the values attained by a conventional single fluid nozzle. This is an important consideration especially at surface temperatures beyond 650<sup>0</sup>C because of the Liedenfrost phenomenon.

Modern air mist nozzle designs also help to reduce investment and operation costs in connection with the compressed air control system instrumentation and the consumption of compressed air. The very high volumes of expensive compressed air (constant air pressure operation) consumed by early generations of air mist nozzles are no longer tolerable, Figure 5.

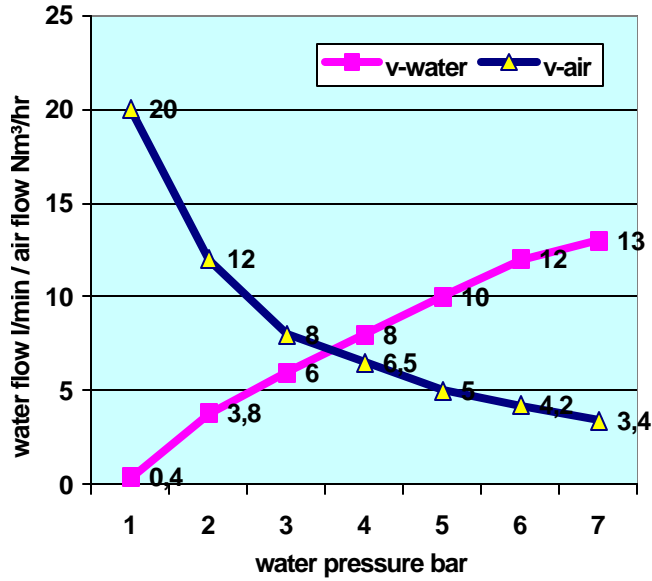

Fig. 5: Old design air mist nozzle type 148.618, p-water 0,5 to 7bars, p-air 2bars constant

This high air consumption was the reason for controlling the air pressure versus the water flow in continuous casting machines of some makers. In some of these machines the air pressure is reduced, at low water flows / pressures and slow casting speeds, to only 1 bar. It goes without saying that the additional air pressure control valves add to the cost of the machine and the cost of maintenance. They also represent an additional potential of failure. Air pressure control also reduces the nozzles turn down ratio because of the common internal mixture design principle.

Recent machine installations in Europe, the US and in Asia by leading plant manufacturers utilise air mist nozzles with a reduced air consumption over the entire turn down ratio, but still maintaining the necessary air-water ratio at the maximum water pressure / flow and casting speed, Figure 6. Because of this nozzle feature air pressure control becomes obsolete. A typical minimum air-water ratio (air in Nm³/hr : l/min for water) at the maximum casting speed is 0,7 to 1,00, however it should not go below 0,5.

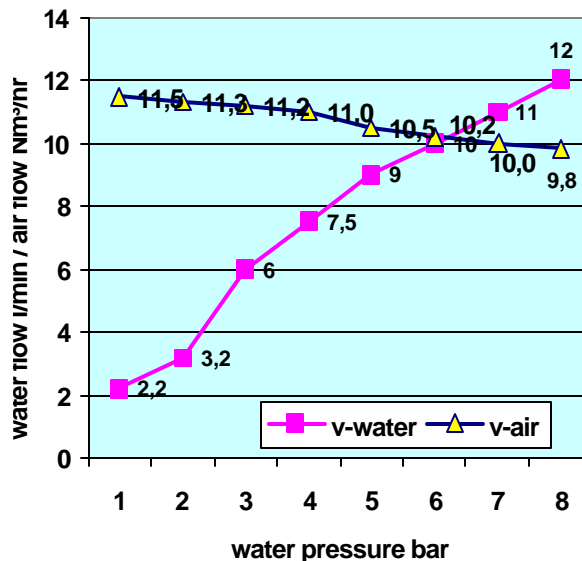

Fig. 6: Air-water flow diagram type 1PM.013.16.16, p-water 0,5bars to 7,0 bars, p-air 2,0bars constant

## WATER TURN DOWN RATIO

Variations in casting speeds as a result of normal operation practises such as start-up, capping off, ladle or tundish changes and because of the product mix (different steel grades and strand dimensions cast) require a certain turn down ratio of the spray nozzles. Another term for the nozzle turn down ratio is control ratio (maximum water flow divided by the minimum water flow). It means the range between the minimum and maximum water flow rate over a defined water pressure range of a given spray nozzle. It is also important to state the air pressure(s) and if the air pressure is constant or variable. It is desired to have air mist nozzles with a wide turn down ratio in order to keep the nozzle varieties in one particular machine at a minimum. Both maintenance and inventory managers appreciate this effort.

Latest achievements in air mist nozzle research and development are now providing designs with turn down ratios wider than ever before with a lower air consumption. The flow diagram in Figure 7 of nozzle type 1PM.013.16.17 also shows that a turn down ratio of 1:23 at a constant air pressure of 2,5bars is not impossible between water pressures of 0,5bars and 7bars. This turn down ratio is approximately 2 to 3 times wider compared with common nozzle designs.

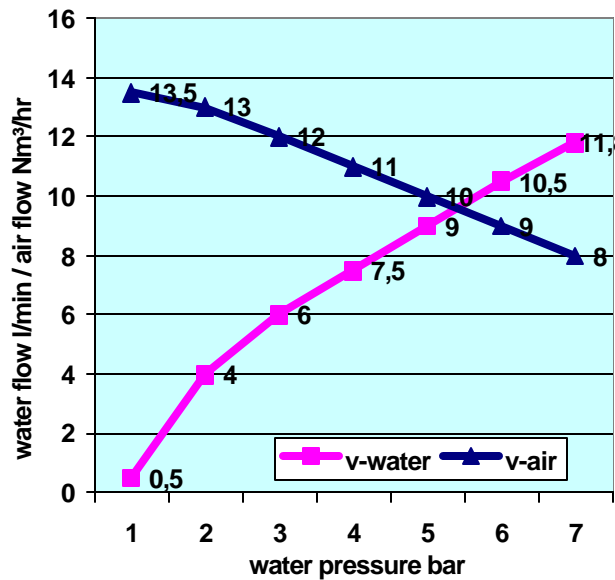

Fig.7: Nozzle type 1PM.013.16.17, p-water 0,5 to 7bars, p-air 2,5bars constant

## WATER DISTRIBUTION

Once the secondary cooling system layout is completed and the mechanical design of the segments is known, it is the spray nozzle manufactures task to design nozzles providing an uniform water distribution across the strand surface and over the entire turn down ratio. Tolerances of +/- 15% from the mean value can be achieved with a multi nozzle arrangement at water pressures between 1,0 and 7,0 bars.

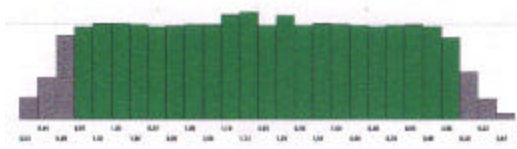

Fig.8

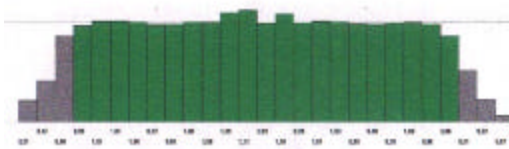

Fig.9

Figures 8 & 9 show water distribution measurements of a twin nozzle (type 1PM.013.16.16) arrangement. The nozzle pitch was 400mm, the spray height 200mm, and the air pressure was 2bars constant in both cases. Figure 8 represents the measurement at 1bar water pressure and Figure 9 the 7bar water pressure measurement. The maximum difference is 13,9% over and 11,2% below the mean value. The spray width stays constant at 1300mm which is another achievement of modern air mist nozzles technology.

In order to widen the turn down ratio it is common to apply a minimum water pressure of 0,5bar. At such a low pressure however, the spray widths of the two nozzles is reduced resulting in a lower water density in the overlap area. The difference in water distribution can drop as much as 50% below the mean value. This disturbing fact led to further HTC measurements focussing on the overlap area at low water pressures. The sprays were directed in one line at 0° offset angle, Figure 10.

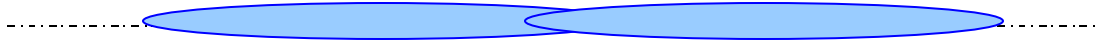

Fig. 10: Positioning of the nozzle foot prints in the impact area

The measurement performed with two air mist nozzles (nozzle axis at Z positions 0 and 400mm), at 0,5bars water pressure and 2bars air pressure, confirmed a low overall HTC but showed a surprisingly little drop of the HTC in the overlap area (Z position 200mm), Figure 11. Hence, surface defects in the overlap area are neither to expected nor experienced in existing installations.

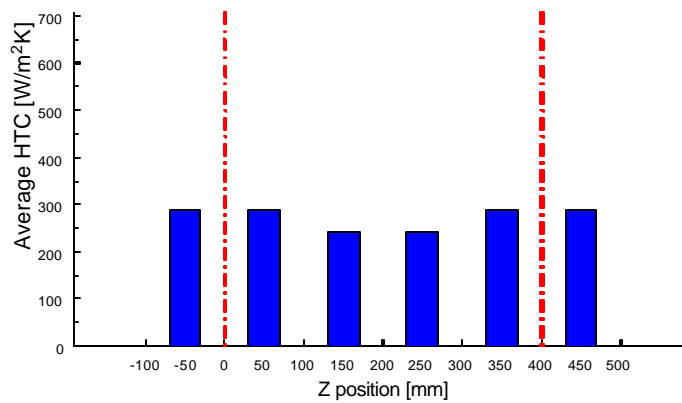

Fig. 11: HTC measurement 2 nozzles type 1PM.013.16.16, p-water 0,5bars, p-air 2,0 bars constant, pitch=400mm, spray height=200mm

Tight water distribution tolerances help to minimize transverse and corner cracks. Because of the convergence of the spray and the effect which the air-water ratio has on the spray jet, their nominal spray angles can no longer be the only design criteria for a multi nozzle arrangement. It is the spray nozzle manufacturer who shall be responsible for the uniformity of the water distribution across the strand width over the entire turn down ration. Tolerances must be specified for every machine because of the different boundary conditions.

## NEW METHODS OF NOZZLE MOUNTING AND HEADER PIPE DESIGNS

Because of their internal mixture, air mist nozzles require two separate feed pipes for compressed air and water. Until recently small diameter hydraulic pipes were used to feed the fluids and to hold the nozzles in place. Only in special cases, where one fluid was fed directly by a hose, additional supports were provided. The conventional air mist nozzles mounted on these small pipes are hidden inside the segment frame work as shown in Figure 12.



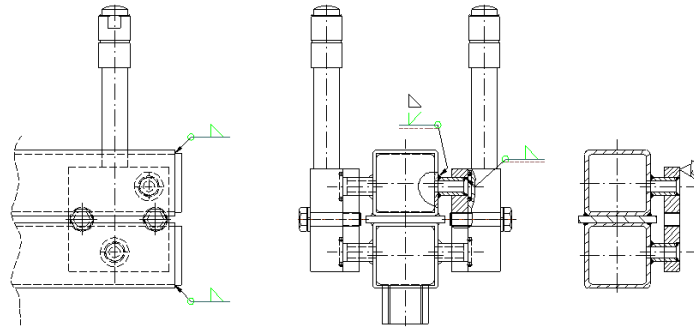

Fig.14: Air mist nozzle with vertical plate connection and square pipe header manifold

Small diameter fluid feed pipes are no longer necessary. All nozzles are mounted outside of the framework at the rear side of the segment with only the nozzle pipe, carrying the spray tip, reaching down to the spray position. A very rigid header pipe and a nozzle self alignment is the result. The nozzle spray position is always secured. A “Hoseless” fluid supply system becomes also possible.

In order to maintain an identical nozzle length in one segment, the nozzles are bolted onto adaptor plates of a tailored length to compensate for the in built bending radius, Figure 15.

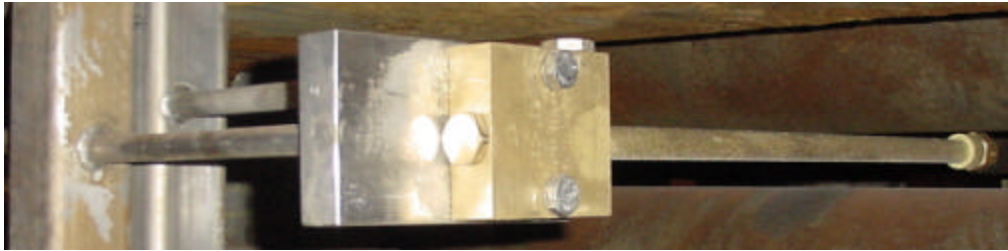

Fig. 15: Air mist nozzle with vertical plate connection and adaptor plate(SGA1,Salzgitter/Germany)

Nozzle staggering between the roller gaps within one segment becomes much easier since different nozzle positions can be served from only one header pipe manifold. Nozzle staggering is one method to equalize the water distribution along the strand in length direction with the intention to eliminate surface defects and cracks. Figure 16 shows such a design with the left and middle nozzles installed in the same plane (roller gap) and the right nozzle in the plane above and below.

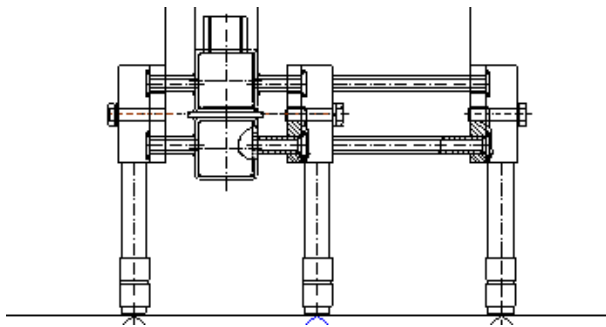

Fig. 16: Staggered nozzles served from only one header manifold

Due to the nozzle mounting position on the segment rear side it is not unusual that the overall nozzle length becomes 1000mm and longer. A strand breakout could lead to an expensive replacement of a number of complete long nozzles. It is therefore, recommendable to install nozzles of the “Split Pipe” , Figure 17, version allowing to separate the front part carrying the nozzle tip and nut only. The nozzle’s vertical plate together with the remaining part of the pipe can be retained. The position of the joint between the two pipe

ends can be designed as per request. A self aligning design identical to the one of the nozzle tip also secures the correct spray direction at this point, Fig.18. A cost saving feature interesting enough especially for top segments near the mould.

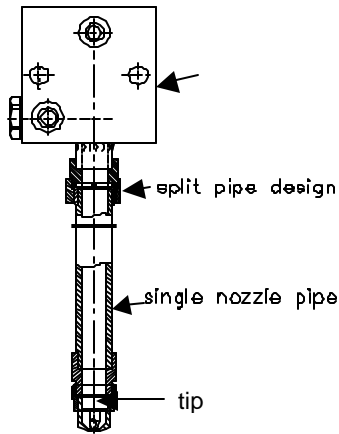

Fig. 17: “Split Pipe” air mist nozzle



Fig. 18: Twin key alignment for tip and pipe

The mixture between compressed air and water takes place away from the hot zone inside the mixing chamber which is an internal part of the vertical plate. Hence, only one single nozzle pipe, exempt of any restrictions, supplies the premixed fluids to the nozzle tip.

The nozzles and header pipes with the vertical plate connection are also an ideal solution for beam blank casters with air mist cooling. Instead of three header pipes, small specially bent fluid feed pipes and a fluid distributor, only two square header pipes with two nozzles bolted on, are required. The advantages described above are also true here. The bends of the nozzle extension pipes can be made to suit. With the aid of the “Split pipe” design the two nozzles on either side can be identical with the front pipe turned by 180°, Figure 19.

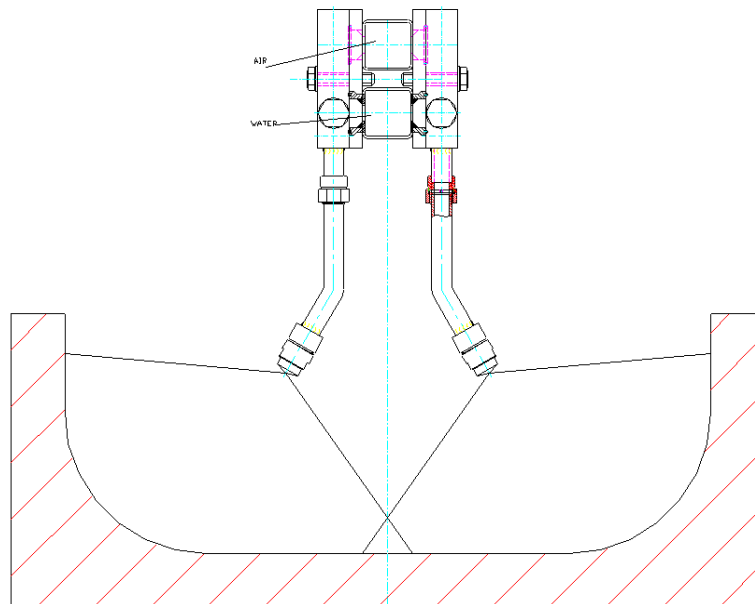

Fig. 19: Air mist nozzle with vertical plate connection for beam blank cooling

## NEW AIR MIST NOZZLES FOR BILLET AND BLOOM CASTING

When air mist cooling becomes necessary for a billet or bloom caster flat jet nozzles may not always be the best choice. This is especially true where the formation of Halfway Cracks is experienced. This type of cracks have shown to be caused by reheating of the surface of the strand after it has passed the sharp heat extraction zone beneath a spray jet. During this reheating process the surface expands and imposes a tensile strain on the interior, hotter and hence weaker regions of the solid shell which then can crack. The use of flat jet nozzles intensifies this effect. Full cone or oval cone nozzles would provide a softer cooling over an extended surface area. These two spray patterns are the standard for single fluid water secondary cooling systems, however there has unfortunately not been an adequate version using air mist. Common full cone air mist nozzles show quite unstable spray performances, very high air consumptions and a tendency to clog very easily. Oval cone air mist nozzles are often rather flat jet nozzles with multi slot orifices. Non uniform spray patterns and the very thin, easy to clog slots, also made these nozzles barely more than a compromise.

With a new generation of full and oval cone air mist nozzles it is now possible to utilise air mist cooling also in billet and bloom casters as effectively as in slab casters. The compact block design allows mounting either on horizontal spray rings but also on vertical "Banana" nozzle headers, Figure 20.



Fig. 20: New full cone or oval cone air mist nozzle in block design

Turn down ratios as wide as 1 : 14 have been achieved at water pressures between 1,0 and 10,0bars at 2bars air constant. Nominal spray angles for circular full cone nozzles range between 60° and 90°. The maximum spray coverage of the oval cone version is 90°x60°. This nozzle can either be installed horizontally to cool blooms or vertically to cool billets.

Free passages with 2,0mm in diameter are approximately three times larger than before for a nozzle size with flows ranging from 0,5 l/min at 1bar water pressure and 5,0 l/min at 7bar water pressure at a constant 2bars air pressure.

Extremely critical cooling problems have successfully been solved in a 5strand bloom machine casting stainless steel rounds with a maximum diameter of 230mm. With a special graphic software the water distribution can be shown in Figure 21 & 22. The visualisation is based on actual low impact water distribution measurements which are performed on a newly developed facility. A 3-dimensional diagrams, Figure 23, gives an impression of the spray foot print and the quality of the water distribution via the impact. For nozzles with narrow spray widths below 50mm, this method of measuring the water distribution is much more accurate, than the common method where the water is collected in zoned pipes.

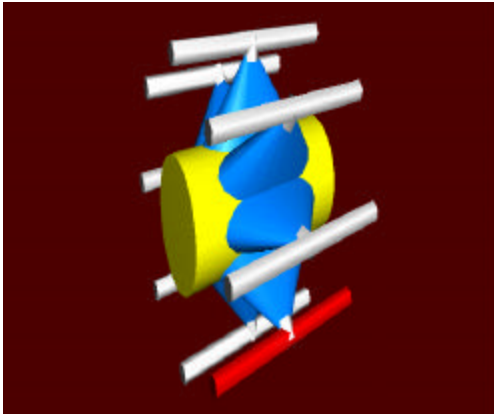

Fig. 21: Foot print of an oval cone air mist nozzle spraying on a round bloom

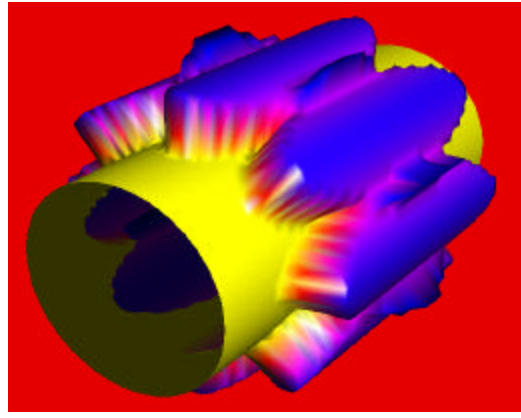

Fig.22: Water distribution simulation oval cone spraying on a round bloom

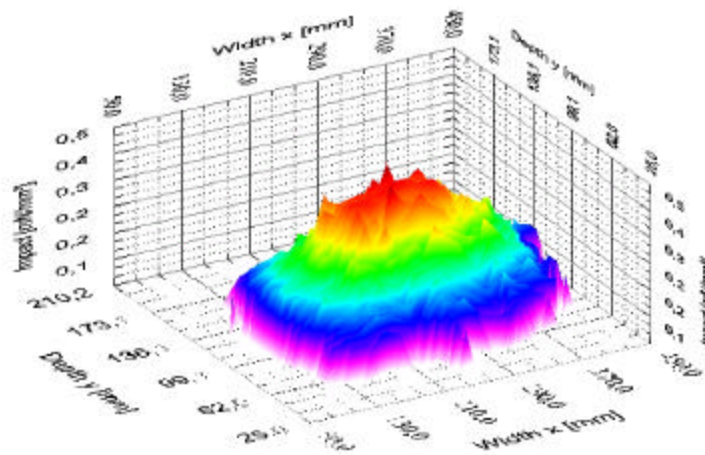

Fig. 23: 3d print of a low pressure impact measurement of an oval cone spray nozzle. Spray thickness in y-axis, spray width in x-axis and impact in z-axis

### Summary

The benefits for the user but also for the machine designer described in this paper are well established facts. The most important of them are:

- Reduced incidence of surface defects and crack formation
- Reduced maintenance and operation costs
- Improvement of operation safety
- Enlargement of caster product mix

The modern air mist nozzle and header pipe technology can be incorporated into new machines as well as into existing casters for billets, blooms, beam blanks, slabs and thin slabs.

### References

- (1) Lothar Bendig, Dr. M. Raudeusky, Dr. J. Horsky "Heat Transfer of Twin Fluid Nozzles for Continuous Casting at Different Test Conditions" at the 13<sup>th</sup> International Conference on Liquid Atomisation and Spray Systems on July 9-11, 1007 in Florence / Italy by the Institute for Liquid Atomisation and Spray Systems ILASS Europe.
- (2) Jürgen Frick, Roman Haap "Improved Secondary Cooling in Continuous Casting" at XXXII Seminario de Fusao, Refino e Solidificacao dos Metais on May7<sup>th</sup> & 8<sup>th</sup>, 2001 in Salvador / Brazil