



MicroSCALEMASTER® descaling nozzles

Series 622



The MicroSCALEMASTER® is the next logical step toward closer nozzle spacing and shorter stand-off distance. It offers the possibility of nozzle spacing of only 1.18" (30 mm) while minimizing the "Swiss cheese effect," i.e. perforating headers with close pitches. Even at that spacing, there is still a sufficient root gap between the holes. The result is a header that can be as close as 2" (50 mm) to the strip for exceptional descaling efficiency with very low flow rates.

Moreover, the small profile of the nozzle base allows for complicated header configurations to descale odd shaped sections and forgings. The stabilizer is almost flush with the back of the base, so it does not require additional clearance within the header. It is even possible to use pipes with reduced diameters and wall thickness due to the small holes involved. These allow you the possibility to mount headers in spaces that would not be practical even with the MiniSCALEMASTER®.

The physical size of the tip limits it to small capacities, but with the efficiencies gained by optimal header and nozzle placement, even low capacity nozzles have the ability to be highly effective.

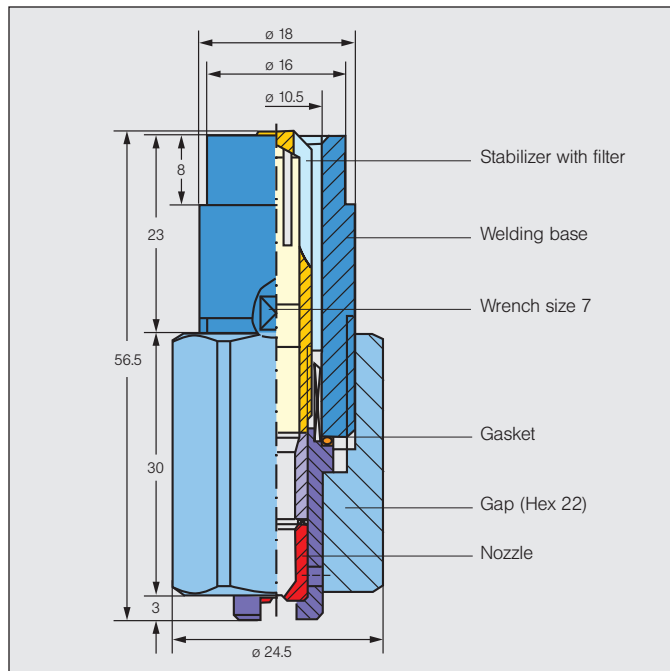

Product Codes for Ordering				Mat. Code	Minimum Free Passage (in.)	Flow Rate (Gallons Per Minute)							
Spray angle						Tungsten Carbide Inserts	700 psi	1000 psi	1500 bar	litres per minute 120 bar	2000 psi	2500 psi	3000 psi
22°	26°	30°	40°	27									
622. 495	622. 496	622. 497	622. 498	○	.042	2.2	2.6	3.2	13.2	3.7	4.2	4.6	5.0
622. 535	622. 536	622. 537	622. 538	○	.045	2.7	3.3	4.0	16.5	4.6	5.2	5.7	6.2
622. 565	622. 566	622. 567	622. 568	○	.047	3.3	4.0	4.8	19.8	5.6	6.2	6.8	7.4
622. 605	622. 606	622. 607	622. 608	○	.059	4.2	5.1	6.2	25.3	7.1	8.0	8.8	9.4
622. 645	622. 646	622. 647	622. 648	○	.063	5.1	6.1	7.5	30.8	8.7	9.7	10.6	11.5

MicroSCALEMASTER® bases, caps and accessories	
Part No.	Description
Bases	
062. 210. 17. 02	Weld Base, 35 mm long
Stabilizers	
062. 250. 30. 00	With Strainer, 35 mm long
Gasket	
095. 015. 1C. 07. 08	Stainless Steel Tip Gasket
Cap	
062. 200. 11. 02	Standard Tip Retainer Cap
Mounting & Assembly Accessories	
062. 290. 01. 00	Alignment Tip, Right Hand
062. 290. 01. 01	Alignment Tip, Left Hand
062. 290. 01. 02	Alignment Tip, Center
095. 009. 00. 13. 77	Disassembly Tool & Tip Extractor Assembly

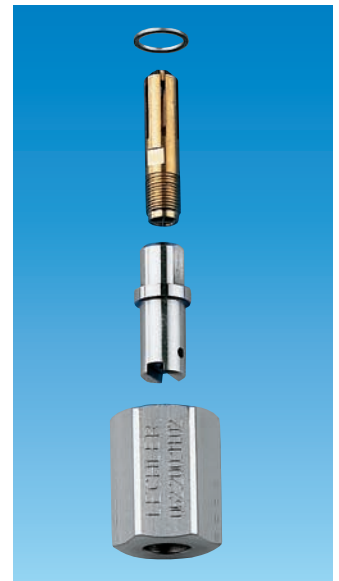

MicroSCALEMASTER® components

