

Roll cooling flat fan nozzle

Series 6E

Patented

The correct alignment of the roll cooling nozzles on the spray header is essential for optimal roll cooling. Flat jets are the preferred spray pattern for roll cooling, therefore only a self aligning nozzle design provides the operation safety required in a modern rolling mill.

All flat jet nozzles of the Lechler series 6E4 and 6E5 come with an automatic self aligning feature which ensures that

every nozzle will always be installed under the correct spray offset angle towards the roll center line.

No welding nipple is required for the 6E nozzle series because the tip geometry can be machined directly into a front plate of a box type spray header. A hollow nozzle nut holds the nozzle tip in place. This simple but innovative design does make all the

welding nipples and the intermediate nozzle plate obsolete resulting in significant cost savings. Another positive aspect is the reduction of the overall weight and outer dimensions of box type headers.

The correct offset angle is machined directly into the header front plate and does not depend on the nozzle tip. The two keys on the nozzle tip are

always in line with the flat jet spray axis.

This prevents wrong fabrication caused by design mistakes.

The nozzle tip seals metalically against the bottom of the header plate machined surface.

The Spray has a parabolic liquid distribution which is ideal for a multi nozzle header arrangement.

- Parabolic liquid distribution
- Automatic nozzle alignment
- High operation safety
- No welding nipples required
- Simplifies the design of boxtype headers because:
 - No welding nipples required
 - Reduces header weight
 - Reduces outer header dimension
 - Reduces header costs significantly

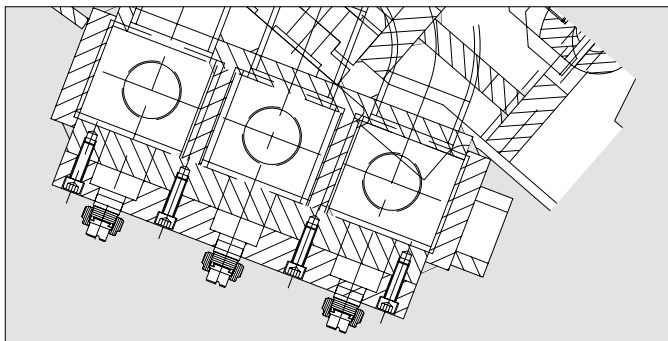

Example of conventional box type header

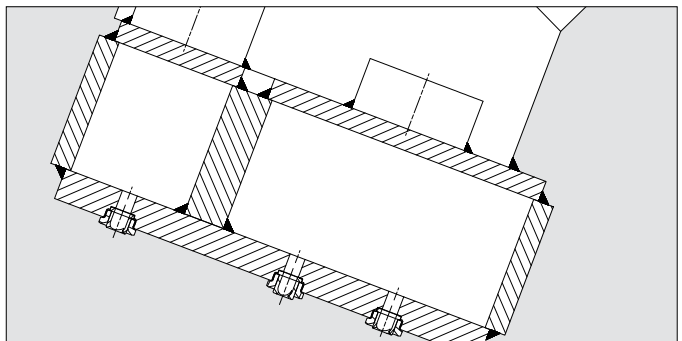

Example of new box type header with 6E series nozzle

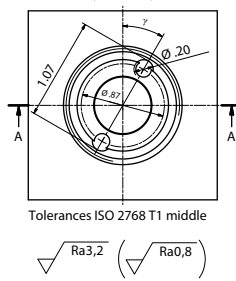
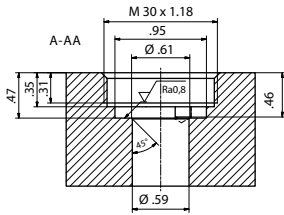

Spray width [B] at p=45 psi

	H 10 in	H 20 in
6E4.721 - 6E4.921	3.94	7.87
6E4.941 - 6E5.201	4.53	8.27
6E4.722 - 6E4.962	5.91	11.81
6E4.982 - 6E5.202	6.3	11.81
6E4.723 - 6E4.963	8.66	17.32
6E4.983 - 6E5.203	9.84	19.29
6E4.724 - 6E4.964	12.99	24.8
6E5.984 - 6E5.204	13.39	25.2

Accessories

Weight .9 lbs

Blind Tip **06E.490.1Y**
for pressure testing

Weight .9 lbs

Hollow-core **06E.400.11** (AISI 430 F)
06E.400.17 (316 SS)
screw **06E.400.30** (brass)

Material AISI 430 F:
Non austenitic stainless steel

Ordering no.				Mat. no.	Equivalent Orifice diam. (in.)	Flow Rate (Gallons Per Minute)													
Type						316 SS 17	Brass 30	10 psi		20 psi		40 psi		60 psi		80 psi		100 psi	
Spray Angle								10	20	40	60	80	100	10	20	40	60	80	100
20°	30°	45°	60°			psi	psi	psi	psi	psi	psi	psi	psi	psi	psi	psi	psi		
6E4. 721	6E4. 722	6E4. 723	6E4. 724	○	○	.08-.10	0.98	1.38	6,30	1.95	2.39	2.76	3.09						
6E4. 761	6E4. 762	6E4. 763	6E4. 764	○	○	.09-.11	1.24	1.76	8,00	2.48	3.04	3.51	3.92						
6E4. 801	6E4. 802	6E4. 803	6E4. 804	○	○	.10-.13	1.55	2.19	10,00	3.10	3.80	4.39	4.91						
6E4. 841	6E4. 842	6E4. 843	6E4. 844	○	○	.12-.14	1.94	2.74	12,50	3.88	4.75	5.49	6.13						
6E4. 881	6E4. 882	6E4. 883	6E4. 884	○	○	.13-.16	2.48	3.51	16,00	4.96	6.08	7.02	7.85						
6E4. 921	6E4. 922	6E4. 923	6E4. 924	○	○	.16-.17	3.10	4.39	20,00	6.21	7.60	8.78	9.81						
6E4. 941	6E4. 942	6E4. 943	6E4. 944	○	○	.18-.20	3.48	4.91	22,40	6.95	8.51	9.83	10.99						
6E4. 961	6E4. 962	6E4. 963	6E4. 964	○	○	.17-.21	3.88	5.49	25,00	7.76	9.50	10.97	12.27						
6E4. 981	6E4. 982	6E4. 983	6E4. 984	○	○	.17-.20	4.34	6.14	28,00	8.69	10.64	12.29	13.74						
6E5. 001	6E5. 002	6E5. 003	6E5. 004	○	○	.19-.23	4.89	6.91	31,50	9.77	11.97	13.82	15.45						
6E5. 011	6E5. 012	6E5. 013	6E5. 014	○	○	.19-.23	5.20	7.35	33,50	10.39	12.73	14.70	16.44						
6E5. 041	6E5. 042	6E5. 043	6E5. 044	○	○	.22-.26	6.21	8.78	40,00	12.41	15.20	17.55	19.62						
6E5. 061	6E5. 062	6E5. 063	6E5. 064	○	○	.23-.26	6.98	9.87	45,00	13.96	17.10	19.75	22.08						
6E5. 081	6E5. 082	6E5. 083	6E5. 084	○	○	.26-.29	7.76	10.97	50,00	15.51	19.00	21.94	24.53						
6E5. 121	6E5. 122	6E5. 123	6E5. 124	○	○	.29-.33	9.77	13.82	63,00	19.55	23.94	27.65	30.91						
6E5. 161	6E5. 162	6E5. 163	6E5. 164	○	○	.33	12.41	17.55	80,00	24.82	30.40	35.11	39.25						
6E5. 181	6E5. 182	6E5. 183	6E5. 184	○	○	.35-.41	13.96	19.75	90,00	27.93	34.20	39.49	44.15						
6E5. 201	6E5. 202	6E5. 203	6E5. 204	○	○	.38-.41	15.51	21.94	100,00	31.03	38.00	43.88	49.06						

Example Type + Material no. = Ordering no.
for ordering: 6E4. 721 + 17 = 6E4. 721. 17

Subject to technical modifications

Conversion formula for the above series: $V_2 = V_1 \sqrt{\frac{P_2}{P_1}}$